

ARA 80|BM 150

ARA 100|BM 150

**Ersatzteilliste
Reinigungsautomat**

**Spare parts list
Scrubber dryer**

**Catalogue des pièces de rechange
Auto-laveuse**

**Elenco pezzi di ricambio
Lavasciuga pavimenti**

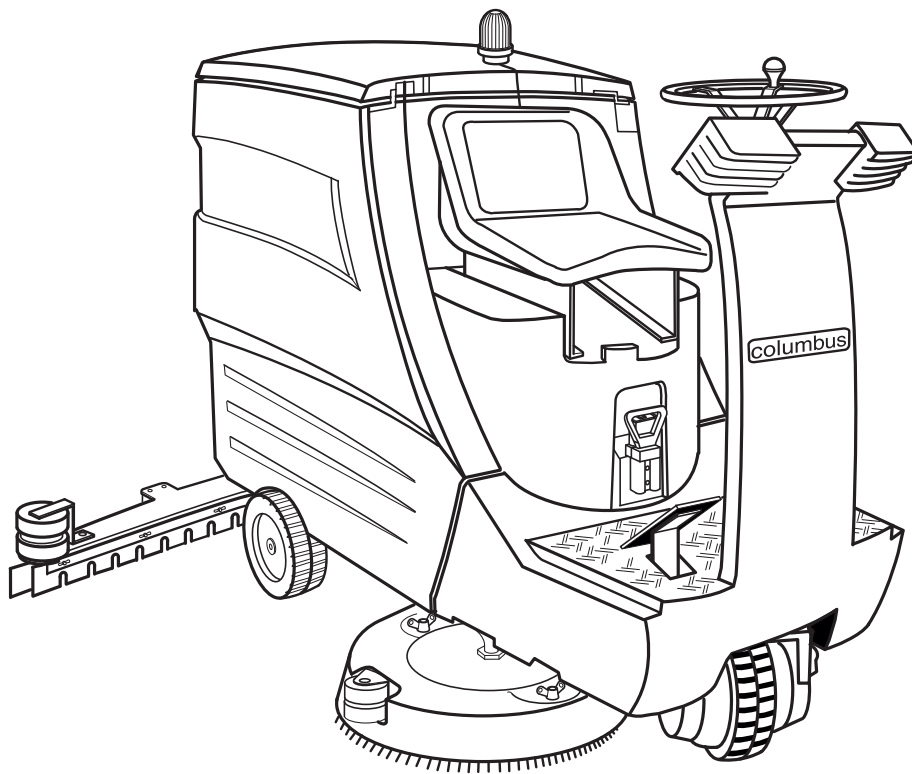

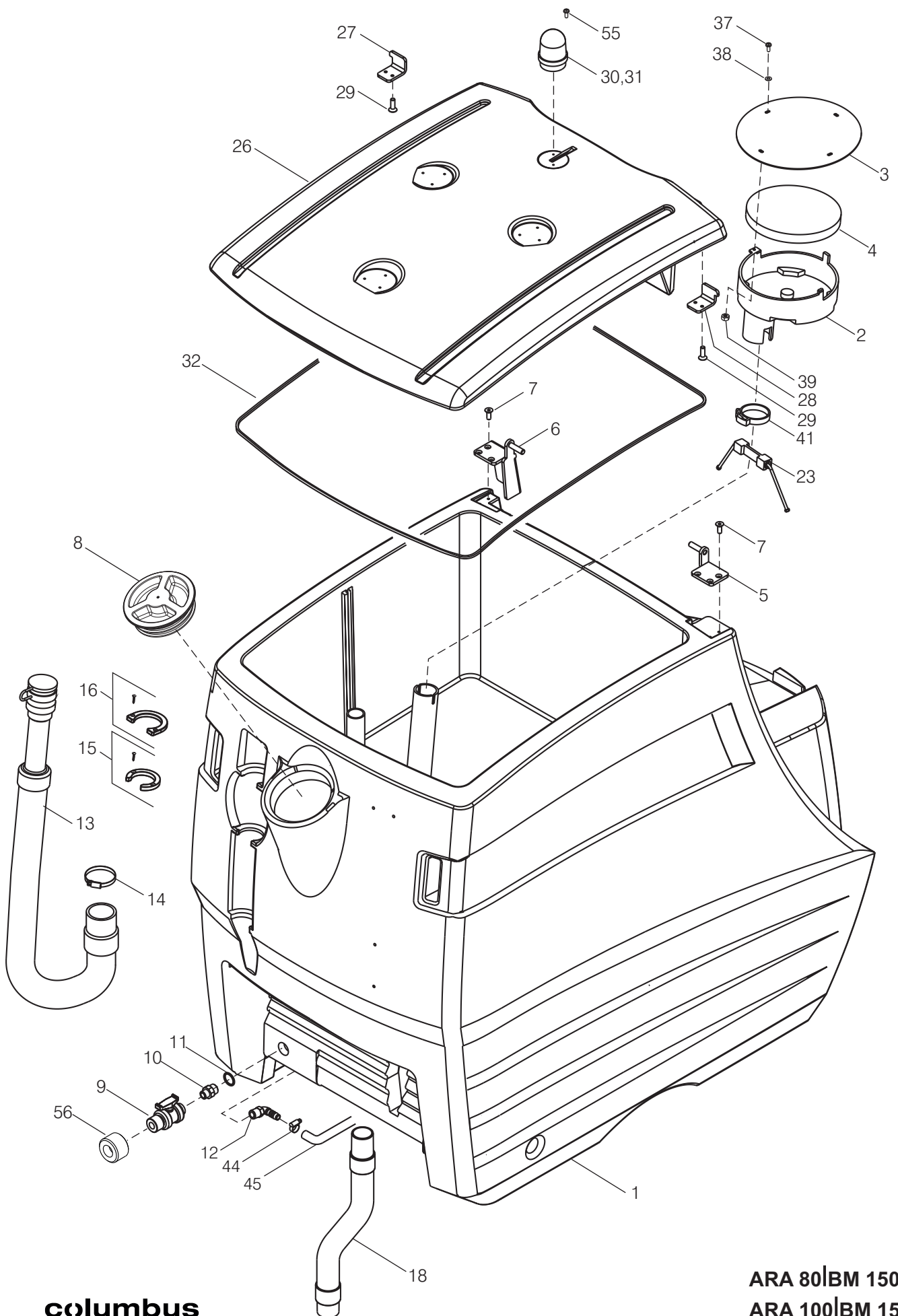

columbus

**ARA 80|BM 150
ARA 100|BM 150**

Tank

Pos	Art.Nr.	Stück	Bezeichnung	Description	Designation	Descrizione
1	20673100	1	Tank	tank	Réservoir	serbatoio
2	20665500	1	Prefiltertopf	prefilter pot	Préfilter pot	vaso filtro
3	20665600	1	Prefilterdeckel	prefilter cover	Couvercle de préfiltre	coperchio filtro
4	20665700	1	Prefilter	prefilter	Préfilter	filtro
5	20671300	1	Schwenklager rechts	swinging piece right	Palier pivotant droite	cuscinetto oscilante, destro
6	20671500	1	Schwenklager links, geschlossen	swinging piece left	Palier pivotant gauche	cuscinetto oscilante, sinistro
7	20220000	6	Senkschraube M 6x16	countersunk screw M6x16	Vis à tête noyée M6x16	vite a testa svasata M6x16
8	21368300	1	Tank-Schraubdeckel	screw lid	Couvercle de réservoir	coperchio
9	20625100	1	Kugelhahn PVC R1/2	ball valve	Robinet à bille	rubinetto R1/2
10	20625200	1	Reduziernippel R3/4-R1/2	reduction nipple	Pièce de réduction	nipolo di riduzione R3/4-R1/2
11	20093300	1	O-Ring 22x3	gasket 22x3	Joint rond	giunto 22x3
12	20805300	1	Winkelschlauchtülle 1/2"	hose bush 1/2"	Tubulure équerre filetée	raccordo tubo, angolare 1/2"
13	21526000	1	SW-Ablaufschlauch PU	run-off hose	Tuyau de vidange	tubo scarico
14	21373200	1	Schlauchschele LA40...60	hose clamp	Collier	fascetta tubo
15	20616930	1	Klemmring BG	clip	Bague de serrage	anello di serraggio
16	20798230	1	Halterung f.Schlauch	hose support	Support	supporto per tubo flessibile
18	21525300	1	Saugschlauch NW38	suction hose	Flexible d'aspiration	tubo aspiratore
21	20789800	1	Grobschmutzsieb	screen	Crible	filtro
23	20772130	2	Fühler kpl.	detecting element	Détecteur	rilevatore
26	20673200	1	Schmutzwasser-Deckel	lid	Chapeau du bidon à roui	coperchio serbatoio
27	20671100	1	Scharnier links	hinge left	Charnière gauche	cerniera, sinistra
28	20671200	1	Scharnier rechts	hinge right	Charnière droite	cerniera, destra
29	20102500	4	Senkschraube M 5x16 DIN7991	countersunk screw M5x16	Vis à tête noyée M5x16	vite a testa svasata M5x16
30	20673000	1	Blinkleuchte	flashing lamp	Clignotant	fanale lampeggiatore
31	20672900	1	Glühlampe 24V	incandescent lamp	Lampe à incandescence	lampada ad incandescenza
32	50798500	2,650 m	Deckeldichtung	lid gasket	chape d'étanchéité	guarnizione coperchio
37	20001200	1	Linsenschraube M4x10	lens screw M4x10	Vis à tête bombée M4x10	vite tc M4x10
38	20000300	1	Scheibe 4,3 DIN125	Washer 4,3	Rondelle 4,3	rondella 4,3
39	20007100	1	6-Kantmutter M4 stopp	hex nut M4	Écrou M4	dado esagonale M4
41	20830600	1	Klemme Ø50-53,5	clamp Ø50-53,5	Collier Ø50-53,5	morsetto Ø50-53,5
44	20272500	1	Schlauchschele LA12...20	hose clamp	Collier LA12...20	fascetta tubo
45	50680800	1	PVC-Gewebeschlauch Ø13 L=730mm (Tank zu Filter)	hose Ø13 L=730mm	Tuyau	tubo Ø13 L=730mm
53	20823200	1	Kabel für Blinklicht	cable flashing lamp	Câble	cavo fenale lampeggiatore
55	20279800	2	Blechschrabe c3,5x19	screw c3,5x19	vis c3,5x19	vite c3,5x19
56	20809600	1	Adapter Kugelhahn	Adapter for the valve	Adaptateur pour valve	Adattatore per la valvola
	70074200	1	"columbus" Aufkleber (vorne)	columbus label	Autocollant "columbus"	etichetta da incollare "columbus"
	70085400	2	Aufkleber ARA 80 BM 150	label ARA 80 BM 150	Autocollant ARA 80 BM 150	etichetta da incollare ARA 80 BM 150
	70085500	2	Aufkleber ARA 100 BM 150	label ARA 100 BM 150	Autocollant ARA 100 BM 150	etichetta da incollare ARA 100 BM 150

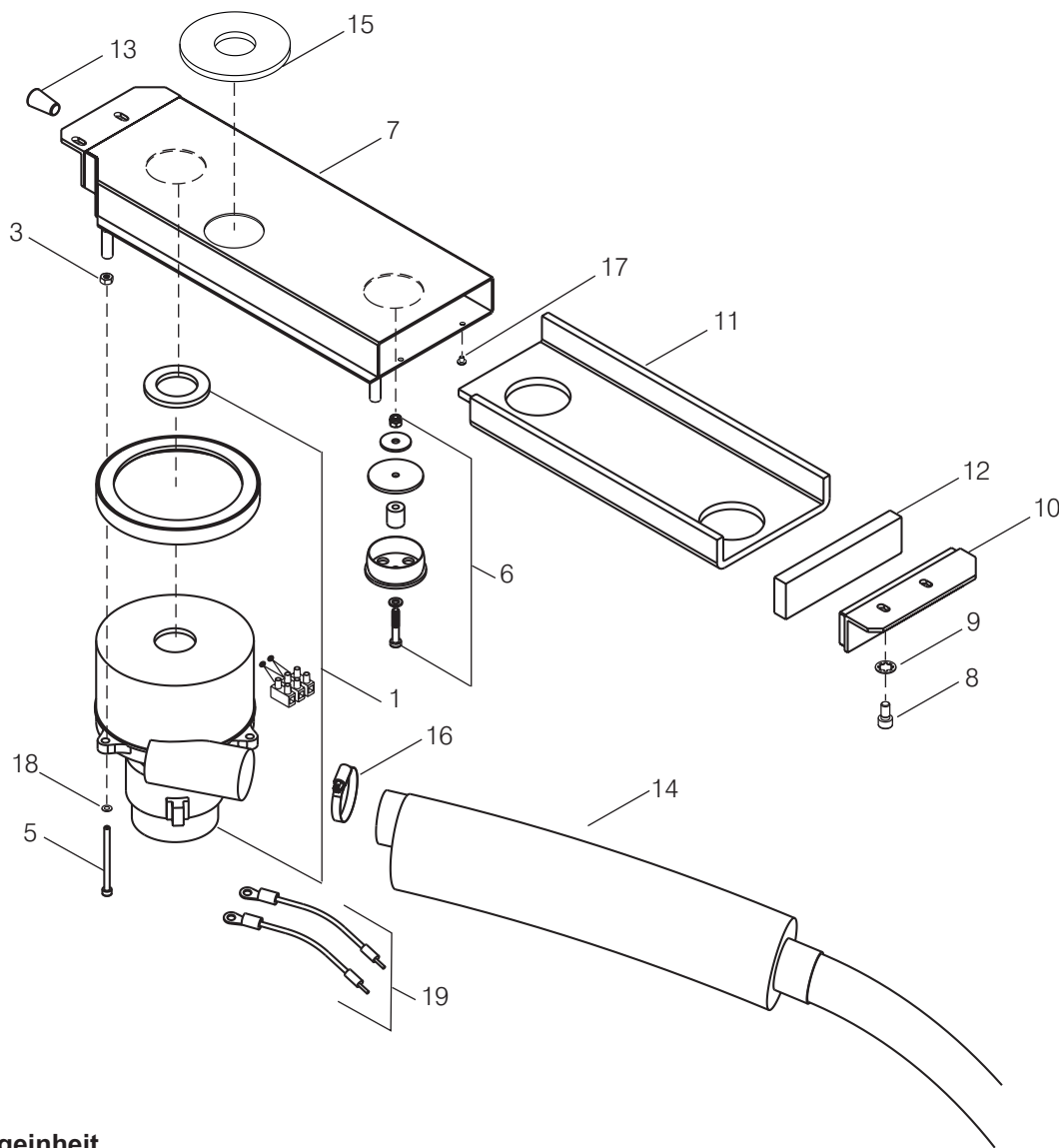

Saugereinheit

Pos	Art.Nr.	Stück	Bezeichnung	Description	Designation	Descrizione
1	20543433	1	Saugmotor 24V kpl.	suction unit	Moteur d'aspiration 24V	motore aspirazione 24V, compl.
3	20005600	3	6-Kantmutter M 5	hex. nut M5	Écrou M5	dado esagonale M5
5	20818500	3	Zylinderschr. M5x70	screw M5x70	Vis cylindrique M5x70	vite M5x70
6	20804230	1	Unterdruckventil	vacuum valve	Clapet de dépression	valvola depressione
7	20678100	1	Saugkasten	suction box	Chambre d'aspiration	cassetto aspiratore
8	20082600	4	Zylinderschr- M6x16	screw M6x16	Vis cylindrique M6x16	vite M6x16
9	20113000	4	Scheibe 6,4 DIN9021	lock washer J 8,4	Rondelle dentée J8,4	disco dentato J8,4
10	20677100	1	Steckwinkel	angle	Angle	angolo
11	20666000	1	Dämmung lang	sound insulation long	Panneau acustique	isolamento acustico
12	20666100	1	Dämmung kurz	sound insulation short	Panneau acustique	isolamento acustico
13	20665900	1	Dichtkonus	jointing	Bouchon	guarnizione di tenuta
14	20661030	1	Schalldämmschlauch	sound insulation hose	Tuyau amortisseur	tubo isol. acustico
15	20808600	1	Dichtung für Saugmotor	suction unit gasket	Garniture	guarnizione di tenuta
16	20219700	1	Schlauchschelle	hose clamp	Collier	fasceta tubo
17	20001500	2	Linsenschraube M4x5	lens screw M4x5	Vis à tête bombée M4x5	vite M4x5
18	20096600	3	Dichtscheibe	washer	Rondelle d'étanchéité	rondella
19	20822800	1	Kabel für Saugmotor	cable for suction unit	Câble	cavo motore aspirazione

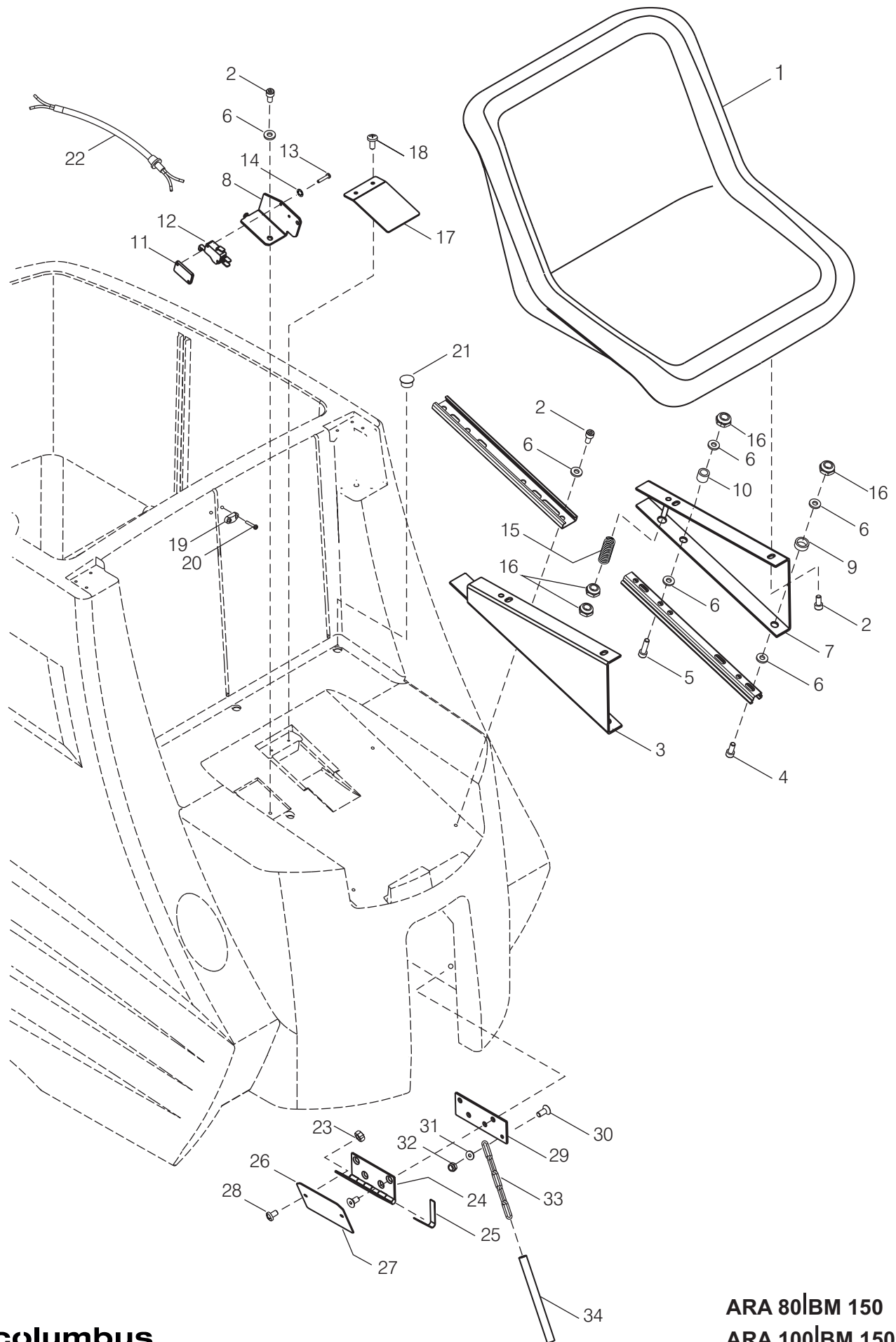

columbus

**ARA 80|BM 150
ARA 100|BM 150**

Fahrersitz

Pos	Art.Nr.	Stück	Bezeichnung	Description	Designation	Descrizione
1	20663600	1	Sitzschale GL28 01 01 G4	seat	Baquet	sedile di guida
2	20152000	8	Zylinderschraube M 8x16 DIN7984	screw M8x16	Vis cylindrique M8x16	vite M8x16
3	20671800	1	Sitzblech rechts	seat support right	Support baquet droite	supporto sedile, destro
4	20076700	2	Zylinderschraube M 8x20 DIN912	screw M8x20	Vis cylindrique M8x20	vite M8x20
5	20279100	2	Zylinderschraube M 8x30 DIN7984	screw M8x30	Vis cylindrique M8x30	vite M8x30
6	20896700	12	Dichtscheibe 8,5	gasket 8,5	Garniture	giunto 8,5
7	20671900	1	Sitzblech links	seat support left	Support baquet gauche	supporto sedile, sinistro
8	20672000	1	Schalterblech	switch plate	Support Commutateur	lamiera interruttore
9	20672100	2	Distanzrohr, vorne	distance tube, front	Distancier	tubo distanziatore, davanti
10	20674300	2	Abstandshülse	distance tube, back	Distancier	tubo distanziatore, dietro
11	20672300	1	Gewindeplatte	plate	Plaque filetée	piastra filettata
12	20958800	1	Microschalter 1006.1514 10(6)A	micro switch	Microcommutateur	microinterrotto
13	20018400	2	Linsenschraube M 3x16 DIN7985	lens screw M3x16	Vis à tête bombée M3x16	vite M3x16
14	20165400	2	Zahnscheibe J 3,2 DIN6797	lock washer J 3,2	Rondelle dentée J3,2	disco dentato J3,2
15	20666300	2	Druckfeder VD-222C	pressure spring	Ressort de compression	molla di compressione VD-222C
16	20280530	4	6-Kantmutter M8 STOPP DIN985	hex. nut M8 STOPP	Écrou M8 stopp	dado esagonale M8
17	20772200	1	Entlüftungsabdeckung	cover	Couverture	coperchio aerazione
18	20654500	2	Schraube KA 50x14 EJ	screw KA 50x14 EJ	Vis KA50x14	vite KA 50x14
19	20046201	2	Kabelschelle	cable clamp	Serre-câble	fascetta cavo
20	20828800	4	Blechschr. 3,5x13	screw 3,5x13	Vis 3,5x13	vite 3,5x13
21	20200000	1	Stopfen Ø11,5	cover Ø11,5	Bouchon	tappo Ø11,5
22	20823100	1	Kabel für Sitzschalter	cable for seat	Câble	cavo sedile
23	20005600	2	6-Kantmutter M 5 DIN934	hex nut M5	Écrou M5	dado esagonale M5
24	20625400	1	Scharnier	hinge	Charnière	cerniera
25	20931200	1	Feder für Scharnier	spring	Ressort	molla
26	20221300	4	Senkschraube M5x10 DIN965	countersunk screw M5x10	Vis à tête noyée M5x10	vite a testa svasata M5x10
27	20782400	1	Riegelblech	locking plate	Fermeture	lamiera chiusura
28	20003200	2	Linsenschraube M5x8 DIN7985	lens screw M5x8	Vis à tête bombée M5x8	vite tc M5x8
29	20928000	1	Platte für Scharnier	plate for hinge	Plaque	pannello
30	20002800	1	Senkschraube M5x12 DIN965	screw M5x12	Vis à tête noyée M5x12	vite M5x12
31	20112900	1	Scheibe 5,3 DIN125	washer 5,3	Rondelle 5,3	rondella 5,3
32	20046000	1	6-Kantmutter M5 STOPP DIN985	hex.nut M8	Écrou M5 Stopp	dado M8
33	20630205	1	Kette 15 Glieder	chain	Chaine	catena
34	50114500	L=350	Isolierschlauch	insulating sleeve	Tuyau isolante	tubetto isolante

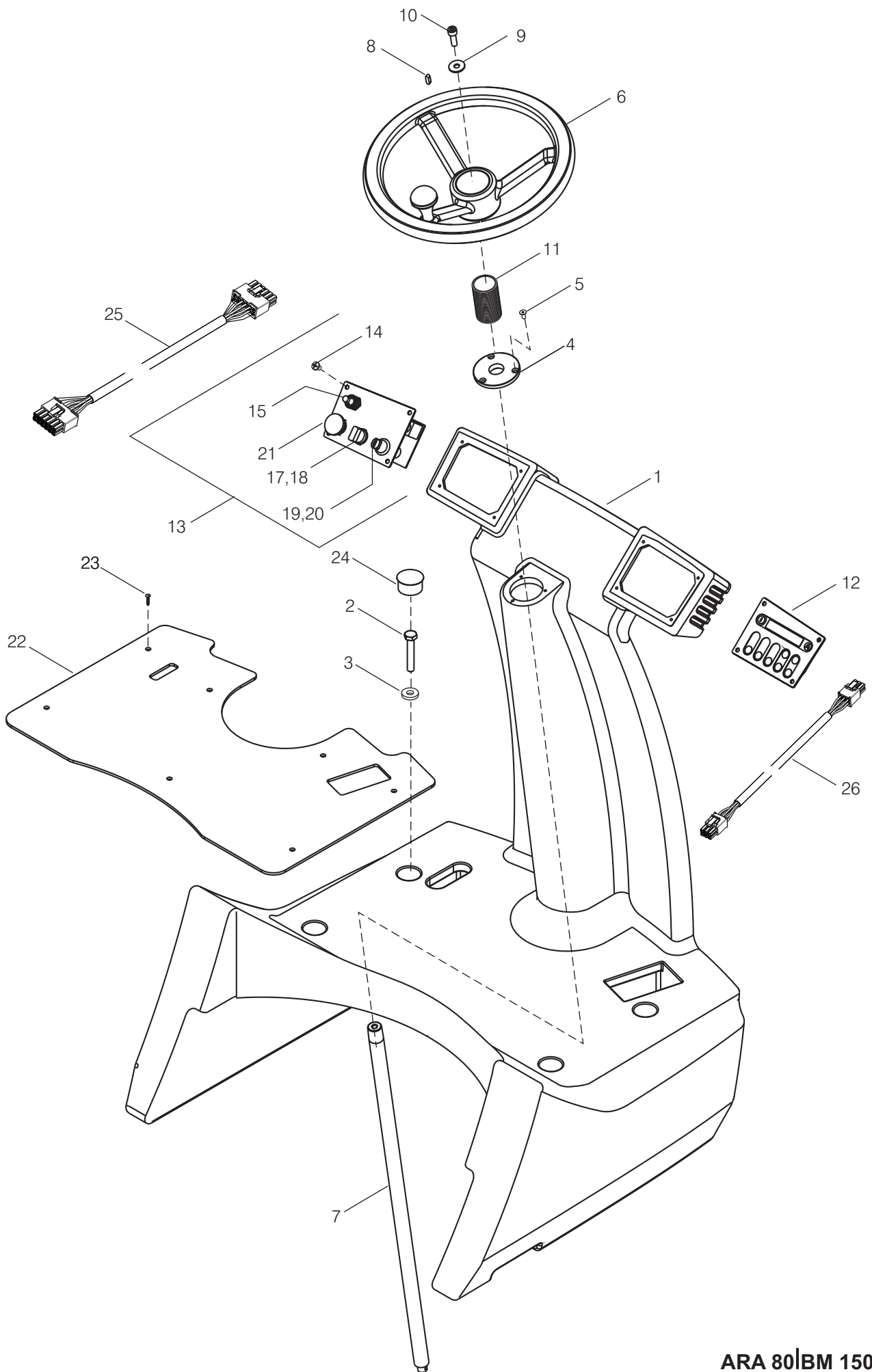

columbus

**ARA 80|BM 150
ARA 100|BM 150**

Steuerpult

Pos	Art.Nr.	Stück	Bezeichnung	Description	Designation	Descrizione
1	20673300	1	Pult ARA	console	Console	pulpito di comando
2	20245100	4	6-Kt Schraube M10x60 DIN 931	screw M10x60	Vis à tête hex.M10x60	vite M10x60
3	20227700	4	Scheibe 10,5 DIN 7949	washer 10,5	Rondelle 10,5	rondella 10,5
4	20666700	1	Lenkbuchse PA	steering bush	Manchon	boccola sterzo
5	20002800	3	Senkschraube M6x12 DIN965	screw M6x12	Vis à tête noyée M6x12	vite M5x12
6	20666800	1	Lenkrad	steering wheel	Volant	volante di guida
7	20678200	1	Lenkwelle	steering shaft	Arbre	albero di guida
8	20666900	1	Pass-Feder 5x5x16 DIN6885	feather key	Ressort d'ajustage 5x5x16	linguetta di aggiustamento 5x5x16
9	20633700	1	Scheibe 8,4 DIN9021	washer 8,4	Rondelle 8,4	rondella 8,4
10	20029200	1	Verbusschraube M8x20	screw M8x20	Vis M8x20	vite M8x20
11	20135101	1	Abdeckung für Lenkachse	hose	Tuyau	tubo flessibile
12	20797901	1	Display-Modul	display-modul	Module d'affichage	modulo display
13	20797902	1	Schalter-Modul	switch-modul	Module de contacteurs	modulo interruttore
14	20003200	8	Linsenschraune M5x8 DIN7985	screw M5x8	Vis à tête bombée M5x8	vite M5x8
15	20921400	1	Kippschalter Fahrrichtung	toggle switch	Interrupteur à bascule	interruttore a bilico
17	21168700	1	Potentiometer 100KOhm	speed controler	Régulateur de vitesse	regolatore di velocità
18	21168830	1	Potentiometerknopf D23 6mm	potentiometer button	bouton potentiomètre	botone potenziometro
19	20632500	1	Schlüsselschalter	switch key	Commutateur à clé	interruttore a chiave
20	20632501	1	Schlüssel	key	Clé	chiave
21	20684000	1	Schalter Hupe	horn switch	Commutateur claxon	interruttore clacson
22	20804900	1	Trittlech	plate	Marchepied	montatoio
23	20279800	7	Senkschraube M6x12 A2 DIN7991	screw M6x12 inox	Vis à tête noyée M5x10	vite M6x12 inox
24	20768900	4	Stopfen Ø35	cover	Bouchon	tappo
25	20855000		Schalter-Modul Kabel	cable switch modul	Câble	cavo modulo interruttore
26	20855100		Display-Modul Kabel	cable display modul	Câble	cavo modulo display

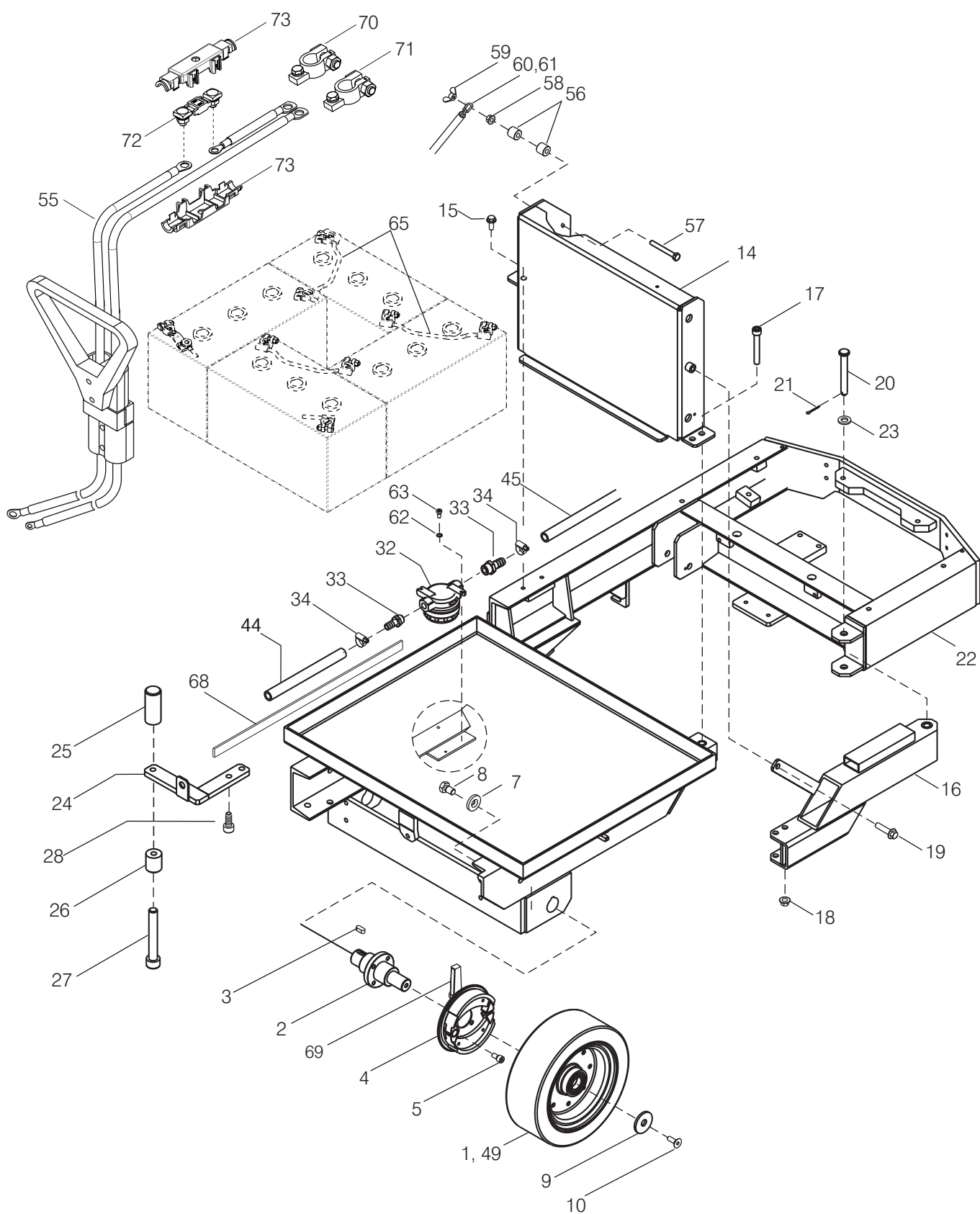

Chassis

Pos	Art.Nr.	Stück	Bezeichnung	Description	Designation	Descrizione
1	20796100	2	Rad Ø250	wheel Ø250	Roue Ø250	ruota Ø250
	20796110	2	Rad Ø250 PU	wheel Ø250 PU	Roue Ø250 PU	ruota Ø250 PU
2	20677200	2	Radachse	axletree	Essieu-axe	asse ruota
3	20667130	2	Pass-Feder 8x7x20 DIN6885	feather key 8x7x20	Ressort d'ajustage 8x7x20	linguetta di aggiustamento 8x7x20
4	21175600	2	Bremse	brake	Frein	freno
5	20152030	8	Zylinderschraube M8x16 DIN7984	screw M8x16	Vis cylindrique M8x16	vite esagonale M8x16
7	20767830	2	Scheibe 13,5x44x4 DIN440	washer 13,5x44x44	Rondelle 13,5x44x4	rondella 13,5
8	20679730	2	6-Kantschraube M12x20 DIN933	hex. nut M12x20	Vis à tête hex.M12x20	vite esagonale M12x20
9	20771000	2	Abdeckscheibe	cover	Rondelle de recouvrement	rondella
10	20030830	2	Senkschraube M 8x25 DIN7991	countersunk screw M8x25	Vis à tête noyée M8x25	vite a testa svasata M8x25
14	20679100	1	Bürsttraverse	crossbar	Traverse	traverse spazzola
15	20195330	2	Verbusschraube M8x20	screw M8x20	Vis M8x20	vite esagonale M8x20
16	20678800	1	Klappeinheit	folding unit	Ensemble basculant	unità ribaltabile
17	20279330	2	Zylinderschr. M10x70	screw M10x70	Vis cylindrique M8x16	vite M10x70
18	20681730	2	Verbussmutter M10	hex. nut M10	Écrou M10	dado esagonale M10
19	20681630	1	Verbusschr. M10x25	hex. screw M10x25	Vis M10x25	vite esag. M10x25
20	20667000	1	Bolzen mit Kopf	bolt with head	Boulon	bullone
21	20682030	1	Splint 3.2x25 DIN94	split pin	Goupille 3,2x25	copiglia 3,2x25
22	20678700	1	Chassis	chassis	Châssis	telaio
23	20082330	1	Scheibe Ø13xØ24x3	washer Ø13	Rondelle 13x24x3	rondella Ø13
24	20802400	1	Düsenanschlagträger	nozzle back stop support	Support	suppoto arresto
25	20802200	1	Düsenanschlagrohr 1	back stop tube 1	Tube 1	tubo arresto 1
26a	20802600	1	Düsenanschlagrohr 2 (nur ARA 100)	back stop tube 2 (ARA 100 only)	Tube 2	tubo arresto 2 (ARA 100)
26b	20815600	1	Düsenanschlag (nur ARA80)	nozzle back stop	Butée	tubo arresto (ARA 80)
27	20279330	1	Zylinderschraube M10x70 DIN912	screw M10x70	Vis cylindrique M10x70	vite tc M10x70
28	20679930	2	Zylinderschr. M10x25	screw M10x25	Vis cylindrique M10x25	vite tc M10x25
32	20760700	1	Filter Inline 3/8"	filter	Filtre	filtro
	20866100	1	Unterteil	lower part	Corp	corpo
	20815800	1	Schraubkappe	screwed cap	Calotte vissée	cappello filettato
	20815700	1	Filtereinsatz	siev	Élément filtrant	elemento filtrante
	211587	1	Formdichtung	gasket, flat	Garniture	guarnizione
33	20681400	1	Schlauchtülle 3/8" Ø12	hose grommet 3/8" Ø12	Douille	beccuccio 3/8" Ø12
34	20272500	3	Schlauchschelle	hose clamp	Collier	fascetta tubo
35	20000330	1	Scheibe 4,3 DIN125	washer 4,3	Rondelle 4,3	rondella 4,3
36	20001200	1	Linsenschraube M4x12 DIN7985	lens screw M4x12	Vis à tête bombée M4x12	vite M4x12
44	50680800	1	PVC-Gewebeschlauch Ø13 L=730mm (Filter zu Tank)	Hose Ø13 L=730mm	Tuyau	tubo Ø13 L=730mm
45	50680800	1	PVC-Gewebeschlauch Ø13 L=730mm (Filter zu Pumpe)	Hose Ø13 L=730mm	Tuyau	tubo Ø13 L=730mm
49	20796102	1	Ersatzreifen für 20796100	spare tire	Bande de rechange	pneumatico di ricambio
	20796112	1	Ersatzreifen PU für 20796110	spare tire	Bande de rechange	pneumatico di ricambio
55	21460531	1	Batteriekabel	cable battery	câbles pour batterie	cavo batterie
56	20928100	2	Buchse	bush	Manchon	canna

Chassis

Pos	Art.Nr.	Stück	Bezeichnung	Description	Designation	Descrizione
57	20588500	1	6 Kantschraube M8x65	hex. screw M8x65	Vis à tête hex.M8x65	vite te M8x65
58	200045930	1	Verbussmutter M8	nut M8	Écrou M8	dado esagonale M8
59	20631330	1	Flügelmutter M8	butterfly nut M8	Écrou à oreilles M8	dado a farfalla M8
60	20630205	1	Kette 15 Glieder	chain	Chaîne	catena
61	50114500	1	Isolierschlauch L=350mm	insulating sleeve	Tuyau isolante	tubetto isolante
62	20008000	2	Zahnscheibe J 6,4	lock washer J 6,4	Rondelle dentée J6,4	disco dentato J6,4
63	20151900	2	Zylinderschraube M6x12 DIN7984	screw M6x12	Vis cylindrique M6x12	vite tc M6x12
65	21387400	3	Batterie- Verbindungskabel	Batterie cable	câble pour accumulateur	cavo batteria
66	20199400	1	Polschuh "-"	binding post "-"	Masse polaire "-"	morsetto "-"
67	20671000	1	Winkel- Einschraubstutzen	angle connection	Tubulure équerre filetée	boccola angolare
68	21046200	1	PVC-Streifen	strip	Bande	striscia
69	21175700	1	Hebel für Bremse	lever	Levier	
70	20199300	1	Polschuh plus	binding post "+"	Masse polaire "+"	morsetto "+"
71	20199400	1	Polschuh minus	binding post "-"	Masse polaire "-"	morsetto "-"
72	21460300	1	Streifensicherung 200A	fuse 200A	Fusible 200A	inserto fusibile
73	21460200	1	Sicherungshalter 200A	fuse holder	Support fusible	supporto fusibile

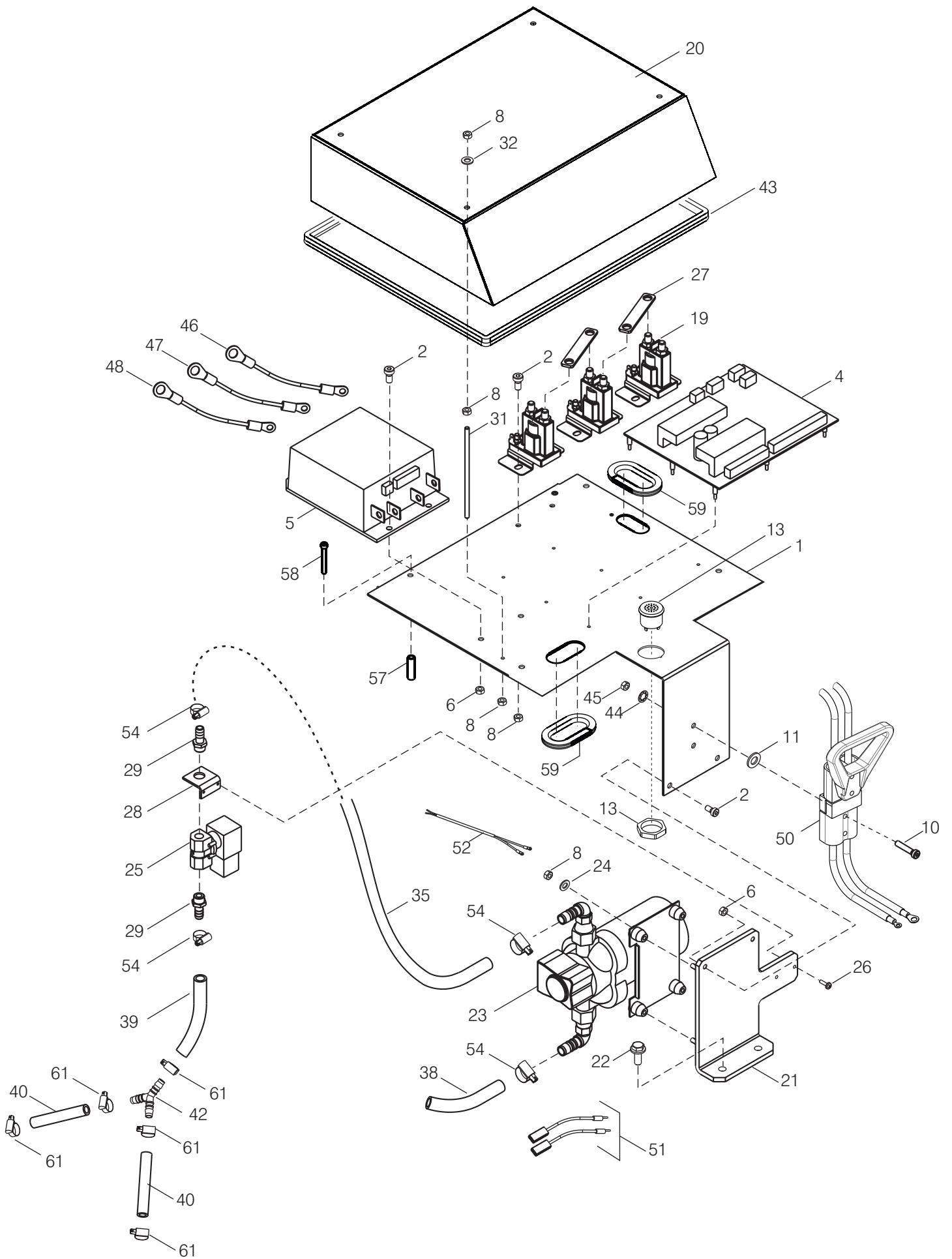

columbus

**ARA 80|BM 150
ARA 100|BM 150**

Elektroblech

Pos	Art.Nr.	Stück	Bezeichnung	Description	Designation	Descrizione
1	20792400	1	Elektroblech bis Masch.Nr.690	plate for electronics	Support électronique	lamiera
1	20940300	1	Elektroblech ab Masch.Nr.691	plate for electronics	Support électronique	lamiera
2	20151900	11	Zylinderschraube M 6x12 DIN7984	screw M6x12	Vis cylindrique M8x12	vite tc M6x12
4	20798001	1	Steuerung 24V ARA bis Masch.Nr.703 Huckepack-Platine ab Masch.Nr.704 (Seriennummer der Maschine angeben)	control board 24V (please indicate the serial number of the machine)	Commande ARA (Numéro de série de la machine à communiquer svp.)	comando elettrico 24V
5	20801800	1	Steuerung Curtis 200A	control board Curtis 200A	Commande Curtis 200A	comando Curtis
6	20002000	4	6-Kantmutter M6 DIN934	hex. nut M6	Écrou M6	hex nut M6
8	20002000	16	6-Kantmutter M6 DIN934	hex. nut M6	Écrou M6	dado esagonale M6
10	20831600	2	Zylinderschraube M 6x35 DIN7984	screw M6x35	Vis cylindrique M6x35	vite tc M6x35
11	20191100	2	Scheibe 6,5x28,0x2,5	washer 6,5	Rondelle 6,5x28x2,5	rondella 6,5
13	21374800	1	Piezo-Buzzer	buzzer	Buzzer	ronzatore
	20666400	1	Summer (für laute Umgebung)	buzzer (for loud surroundings)	Buzzer (pour ambiance bruyantes)	ronzatore (per ambiente rumoroso)
19	20804800	3	Schalterschütz	relais	Relais	relè
20	20803600	1	Elektronikabdeckung bis Masch.690	cover for electronics	Couvercle pour électronique	copertura
	20940400	1	Elektronikabdeckung ab Masch.691	cover for electronics	Couvercle pour électronique	copertura
21	20792300	1	Halter	support	Support	supporto
22	20195300	2	Verbusschraube M8x20	hex. screw M8x20 (10 pieces)	Vis M8x20	vite esagonale M8x20
23	20805200	1	Pumpe 24V	pump 24V	Pompe	pompa 24V
24	20009600	4	Scheibe 5,3 DIN125	washer 5,3 (10 pieces)	Rondelle 5,3	rondella 5,3
25	20855700	1	Magnetventil 24V/DC 2/2W	magnetic valve 24V/DC 2/2W	Electrovalve 24V/DC 2/2W	valvola elettromagnetica 24V/DC 2/2W
26	20132500	2	Blechschaube Bz3,5x13 DIN7983	screw 3,5x13	Vis 3,5x13	vite 3,5x13
27	20829000	2	Brücke	jumper	Pont	lamiera di contatto
28	20855800	1	Winkel für Magnetventil	angle	Angle	angolo valvola
29	20681400	1	Schlauchtülle Ø12 / 3/8"	hose buh Ø12 / 3/8"	Douille	beccuccio Ø12-3/8"
30	20880701	1	Gewindestange M5x105 bis Masch. Nr. 690	screwed bar M5x105	Tige filetée M5x105	asta filetatanM5x105
31	20880702	1	Gewindestange M5x130 bis Masch. Nr. 690	screwed bar M5x130	Tige filetée M5x130	asta filetatanM5x130
31	20958201	4	Gewindestange M6x120 VA	screwed bar M5x120	Tige filetée M5x130	asta filetatanM5x120
32	20009600	4	Scheibe 5,3 DIN125 bis Masch.NR. 690	washer 5,3	Rondelle 5,3	rondella 5,3
32	20096600	4	Dichtscheibe 6,8x16x3 ab Masch.Nr. 691	washer	Rondelle	rondella
33	20005600	6	6-Kantmutter M 5 DIN934	hex. nut M5	Écrou M5	hex nut M5
35	50680800	1	PVC-Gewebes Schlauch Ø13 L=160mm	hose Ø13 L=60mm	Tuyau	tubo Ø13 L=60mm

Elektroblech

Pos	Art.Nr.	Stück	Bezeichnung	Description	Designation	Descrizione
38	50680800	1	PVC-Gewebes Schlauch Ø13 L=730mm	hose Ø13 L=730mm	Tuyau	tubo Ø13 L=730mm
39	50680800	1	PVC-Gewebes Schlauch Ø13 L=230mm	hose Ø13 L=230mm	Tuyau	tubo Ø13 L=230mm
40	50660300	2	PVC-Gewebes Schlauch Ø10 L=270mm	hose Ø10 L=270mm	Tuyau	tubo Ø10 L=270mm
42	20366000	1	Y-Stutzen Ø10	Y-hose bush	Tubulure à Y	beccuccino Y
43	50413600		Kantenschutz L=1,2m	edge protection	Protège-arête	profilo di protezione
44	20008000	1	Zahnscheibe J6,4 DIN 6797	lock washer J6,4	Rondelle dentée J6,4	rondella J6,4
45	20002000	1	6 Kantmutter M6 DIN934	hex. nut M6	Écrou M6	dado esagonale M6
46	20822200	1	Kabel Curtis.Steuerung schwarz	cable Curtis	Câble	cavo Curtis
47	20822400	1	Kabel Curtis-Relais rot	cable Curtis-relay	Câble	cavo Curtis-relè
48	20822300	1	Kabel Relais-Steuerung rot	cable relay	Câble	cavo relè
50	21460531	1	Batteriekabel	cable battery	Câble batterie	cavo batt.
51	20822700	1	Kabel für Pumpe	cable for pump	Câble	cavo pompa
52	20862500	1	Kabel für Magnetventil	cable for valve	Câble	cavo valvola
54	20272500	4	Schaluchschelle LA12...20	hose clamp	Collier	fascetta tubo
57	20125300	2	Buchse Ø10/Ø6,3x35,5 ab Masch.Nr. 691	bush	Bague d'entretoise	distanziale
58	20114300	2	Zylinderschraube M6x50 DIN7984 ab Masch.Nr. 691	screw M6x50	Vis cylindrique M6x50	vite M6x50
59	50368200	2	Kantenschutz L=150mm ab Masch.Nr. 691	protection	Protège	protezione
60	20671000	1	Winkel- Einschraubstutzen	angle connection	Tubulure équerre filetée	boccola angolare
61	20596500	5	Schlauchklemme 17- 18,5	hose clamp	Collier	fascetta tubo

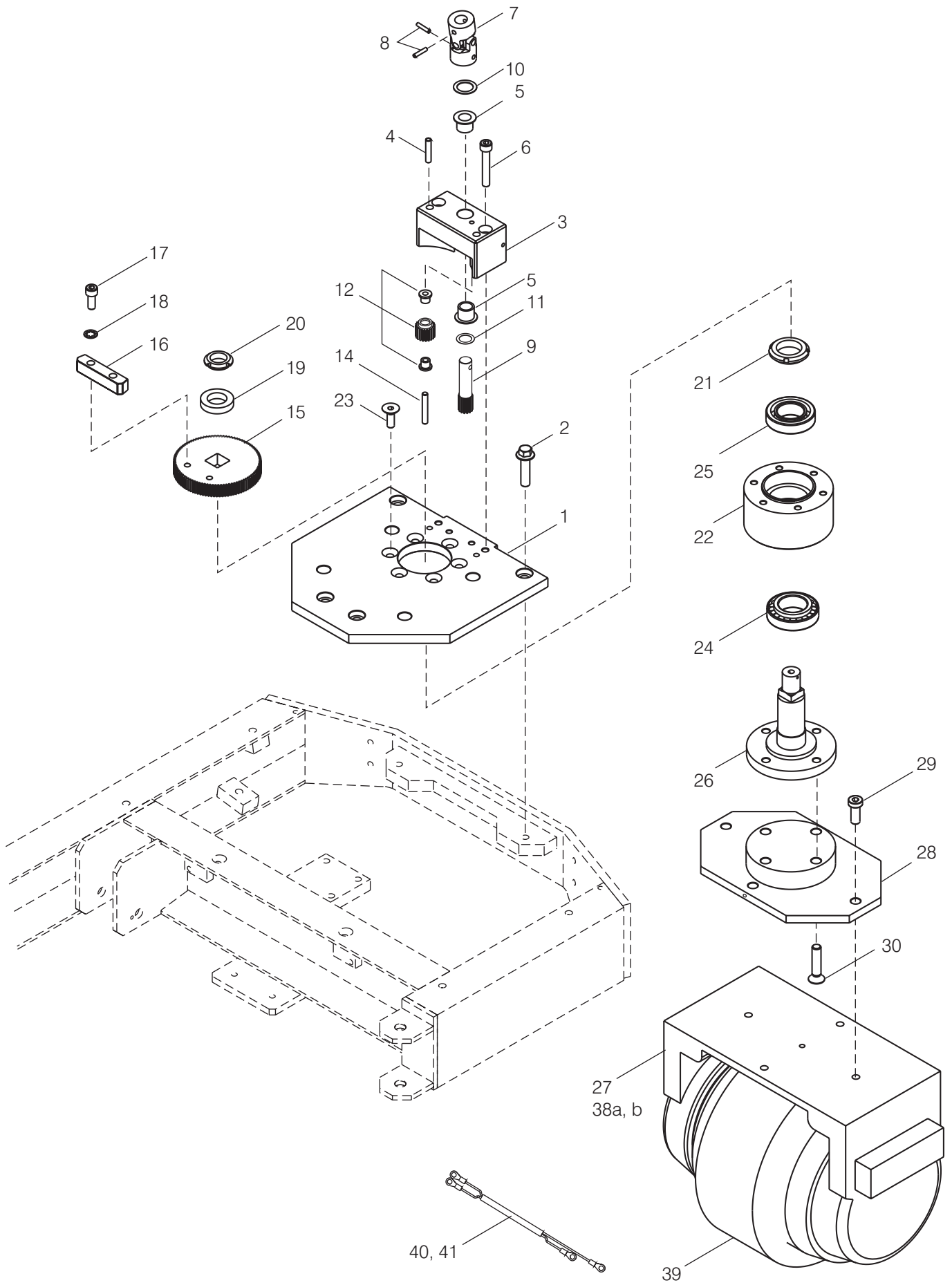

columbus

**ARA 80|BM 150
ARA 100|BM 150**

Lenkeinheit

Pos	Art.Nr.	Stück	Bezeichnung	Description	Designation	Descrizione
1	20677900	1	Trägerplatte	bracket	Support	panello portante
2	20679900	4	Zylinderschraube M10x25 DIN7984	screw M10x25	Vis cylindrique M10x25	vite tc M10x25
3	20815100	1	Zahnradhalter	toothed wheel support	Support rue dentée	supporto ruota dentata
4	20667300	2	Spiral-Spannstift 6x30 DIN7344	spiral pin 6x30	Groupille	spina tenditore 6x30
5	20667400	2	Bundbuchse BB141814 BP25	bush	Manchon	camicia
6	20680000	2	Zylinderschraube M 8x50 DIN7984	screw M8x50	Vis cylindrique M8x16	vite tc M8x50
7	20667700	1	Lenkgelenk	steering knuckle	Articulation	cerniera guidare
8	20667800	2	Spiral-Spannstift 5x30 DIN7344	spiral pin 5x30	Groupille	spina tenditore 5x30
9	20667601	1	Antriebsrad	driving wheel	Roue motrice	ruota motrice
10	20680400	1	Scheibe 15,0x24,0x2,5 DIN433	washer 15x24x2,5	Rondelle 15x24x2,5	rondella 15
11	20667500	2	Pass-Scheibe 14x20x0,5 DIN988	feder washer 14x20x0,5	Rondelle 14x20x0,5	rondella aggiustata
12	20667931	1	Umlenkrad kpl.	deflection wheel cpl.	Rouleau de renvoi	ruota di rinvio compl.
14	20673800	1	Zylinderstift 6x40,5 DIN7	pin 6x40,5	Goupille 6x40,5	asse di rinvio
15	20668301	1	Abtriebsrad	following gear	oue entraînée	ruota secondario
16	20673901	1	Anschlag	end stop	Battée	arresto
17	20279100	2	Zylinderschraube M 8x30 DIN7984	screw M8x30	Vis cylindrique M8x30	vite tc M8x30
18	20005500	2	Zahnscheibe J 8,4 DIN6797	lock washer J 8,4	Rondelle dentée J8,4	disco dentato J8,4
19	20668400	1	Scheibe 22x37x8 DIN7989	washer 22x37x8	Rondelle 22x37x8	rondella 22x37x8
20	20668600	1	Nutmutter M20x1	slotted nut M20x1	Écrou rainuré M20x1	dado dentato M20x1
21	20668500	1	Nutmutter M30x1,5	slotted nut M30x1,5	Écrou rainuré M30x1,5	dado dentato M30x1,5
22	20676600	1	Lageraufnahme	seat bearing	Logement pour palier	alloggiamento cuscinetto
23	20030800	6	Senkschraube M 8x25 DIN7991	countersunk screw M8x25	Vis à tête noyée M8x25	vite a testa svasata M8x25
24	20668100	1	Kegelrollenlager 32x58x17	tapered roller bearing 32x58x17	Roulement à rouleaux	cuscinetto di rulli conici 32x58x17
25	20668200	1	Kegelrollenlager 30x55x17	tapered roller bearing 30x55x17	Roulement à rouleaux	cuscinetto di rulli conici 30x55x17
26	20676500	1	Lenkachse	steering axle	Essieu pilotante	asse guidare
27	20782100	1	Radantrieb MTR MP 250 800W	wheel drive 800W	Entraînement pour roue	motore trazione MTR MP 250 800W
28	20785200	1	Amerplatte	plate	Plaque Amer	panello Amer
29	20679900	4	Zylinderschraube M10x25 DIN7984	screw M10x25	Vis cylindrique M10x25	vite tc M10x25
30	20799800	4	Senkschraube M10x45 DIN7991	countersunk screw M10x45	Vis à tête noyée M6x16	vite a testa svasata M10x45
38a	20878800	2	Kohlebürsten für Klemmkasten	carbon brush-rotor	Balai	spazzola di carbone-rotore
38b	20878801	4	Kohlebürsten für Rotor	carbon brush	Balai	spazzola di carbone
39	20782101	1	Ersatzrad	wheel	Roue (rechange)	ruota
40	20822500	1	Kabel für Fahrmotor	cable for drive motor	Câble	cavo per motore trazione
41	50784900	0,7 m	Schutzschlauch	protection hose	Tuyeau de protection	cavo di protezione

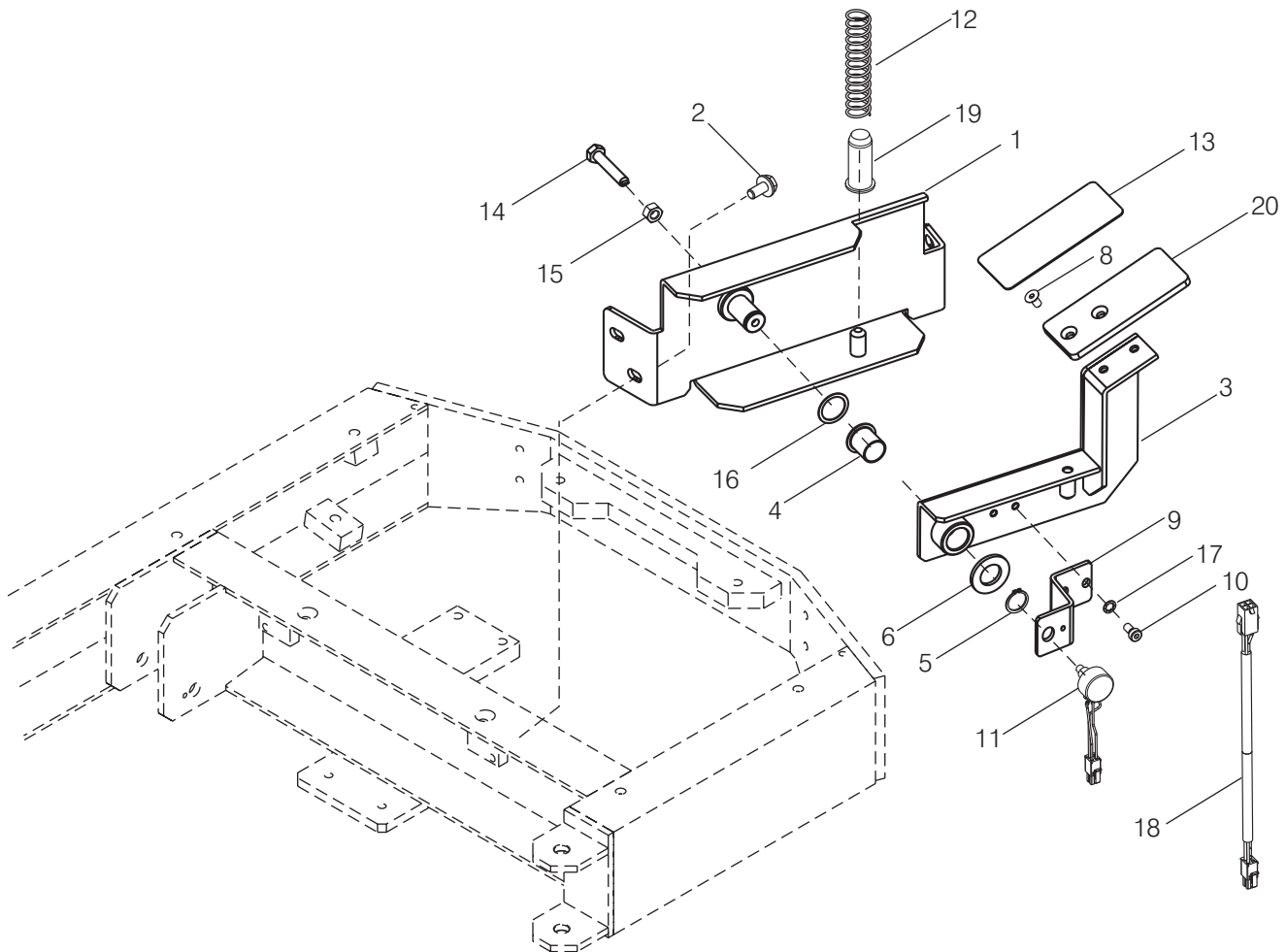

Gaseinheit

Pos	Art.Nr.	Stück	Bezeichnung	Description	Designation	Descrizione
1	20679300	1	Pedalaufnahme	pedal seat	Logement pour pédale	alloggiamento pedale
2	20682200	4	Verbusschr. M8x16	hex. screw M8x16	Vis M8x16	vite esagonale M8x16
3	20677800	1	Trittpedal	pedal	Pédale	pedale
4	20668700	1	Bundbuchse BB1822DU	bush	Manchon	boccola
5	20285100	1	Sicherungsring 18x1,2 DIN471	safety ring 18x1,2	Rondelle de sécurité 18x1,2	anello di sicurezza 18x1,2
6	20680300	1	Scheibe 19,0x34,0x3,0	washer 19x34x3	Rondelle 19x34x3	rondella 19x34x3
7	20674800	1	Trittplatte	step plate	Marchepied	montatoio
8	20047900	2	Senkschraube M6x12 DIN965	countersunk screw M6x12	Vis à tête noyée M6x12	vite a testa svasata M6x12
9	20675000	1	Potiwinkel	potentiometer holder	Angle	angolo potenziometro
10	20151900	2	Zylinderschr. M6x12	screw M6x12	Vis cylindrique M6x12	vite tc M6x12
11	20997700	1	Potentiometer 5K	potentiometer 5K	Potentiomètre	potenziometro 5K
12	20797400	1	Druckfeder VD-232M-	pressure spring	Ressort de	molla di
13	20771100	1	Sandpapier	sand paper	Papier sablé	carta vetrata
14	20771200	1	Stellschraube	adjustable screw	Vis de réglage	vite di regolazione
15	20000500	1	6-Kantmutter M8	hex. nut M8	Écrou M8	dado esagonale M8
16	20222400	1	Ausgleichscheibe	washer	Rondelle de compens.	rondella
17	20008000	1	Zahnscheibe J 6,4	lock washer J 6,4	Rondelle dentée J6,4	disco dentato J6,4
18	20928201	1	Kabel Gaspoti	cable for poti	Câble	cavo potenziometro
19	21041900	1	Federführung	spring guiding	Guidage pour ressort	guida molla
20	20674800	1	Trittplatte			

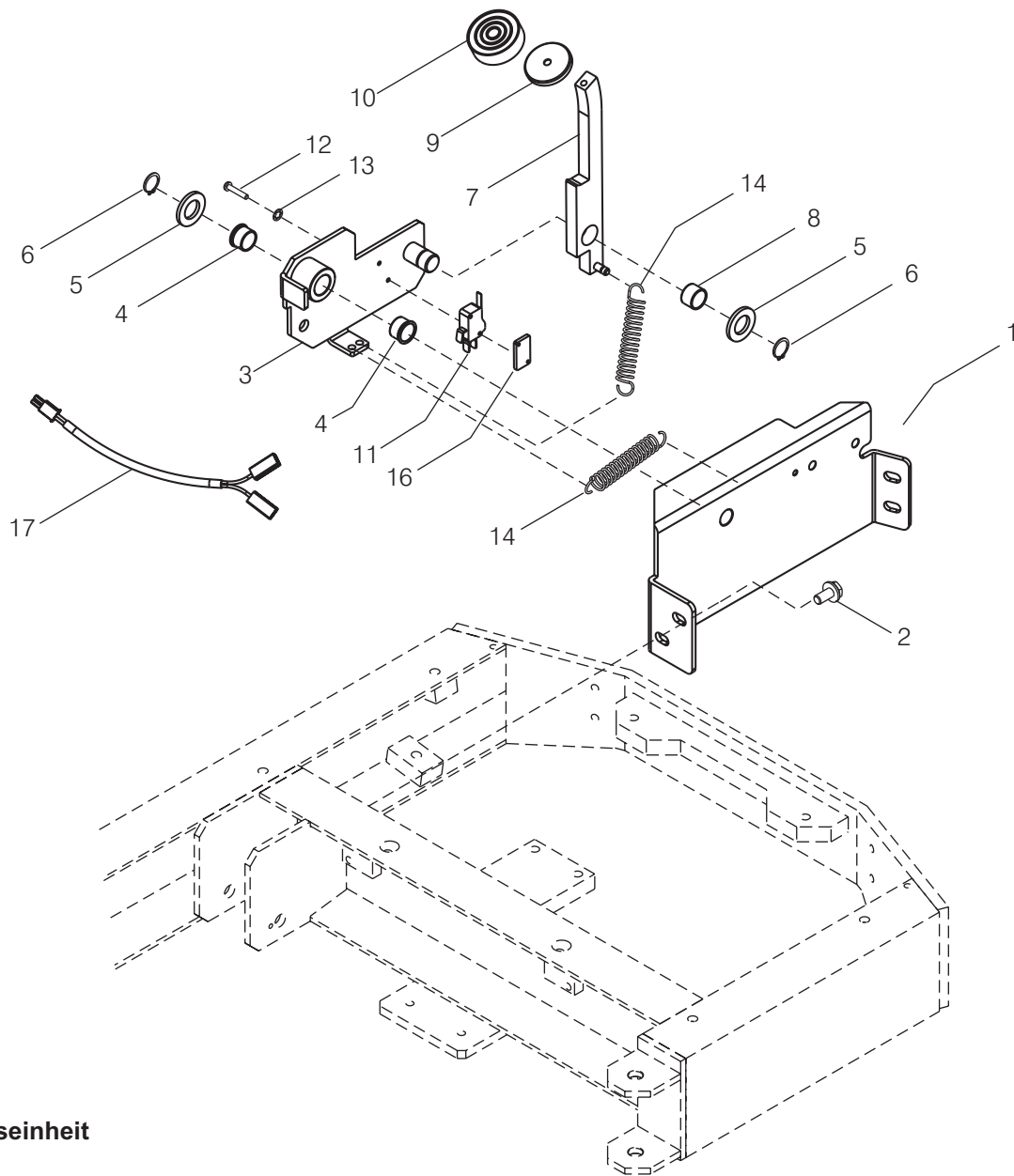

Bremseinheit

Pos	Art.Nr.	Stück	Bezeichnung	Description	Designation	Descrizione
1	20678500	1	Pedalaufnahme	pedal seat	Logement pour pédale	alloggiamento pedale
2	20682200	4	Verbusschraube	hex. screw M8x16	Vís M8x16	vite esagonale M8x16
3	20676800	1	Betätigungsplatte	actuating plate	Plaque d'actionement	panello comando
4	20668900	2	Bundbuchse PBG 161812 F	bush	Manchon	boccola
5	20102800	2	Scheibe 17,0x30,0x3,0	washer 17x30x3	Rondelle 17x30x3	rondella 17
6	20029600	2	Sicherungsring A 16x1	safety ring A 16x1	Rondelle de séc.A16x1	anello di sicur. A16x1
7	20675400	1	Trittpedal	pedal	Pédale	pedale
8	20669000	1	Buchse GFM-161812	bush	Manchon	boccola
9	20673700	1	Trittplatte	plate	Marchepied	montatoio
10	20669100	1	Pedal gummi	pedal rubber	Caoutchouc	gomma pedale
11	20242000	1	Microschalter 1006.1401	microswitch	Microcommutateur	micro interruttore
12	20018400	2	Linsenschraube M3x16	lens screw M3x16	Vís à tête bombée M3x16	vite M3x16
13	20165400	2	Zahnscheibe J 3,2	lock washer J 3,2	Rondelle dentée J3,2	disco dentato J3,2
14	20669300	2	Zugfeder RZ-127I	tension spring	Ressort de traction	molla di trazione
16	20672300	1	Gewindeplatte	screwed plate	Plaque filetée	lamiera filettata
17	20822900	1	Kabel Für Bremse	cable brake	Câble	cavo freno

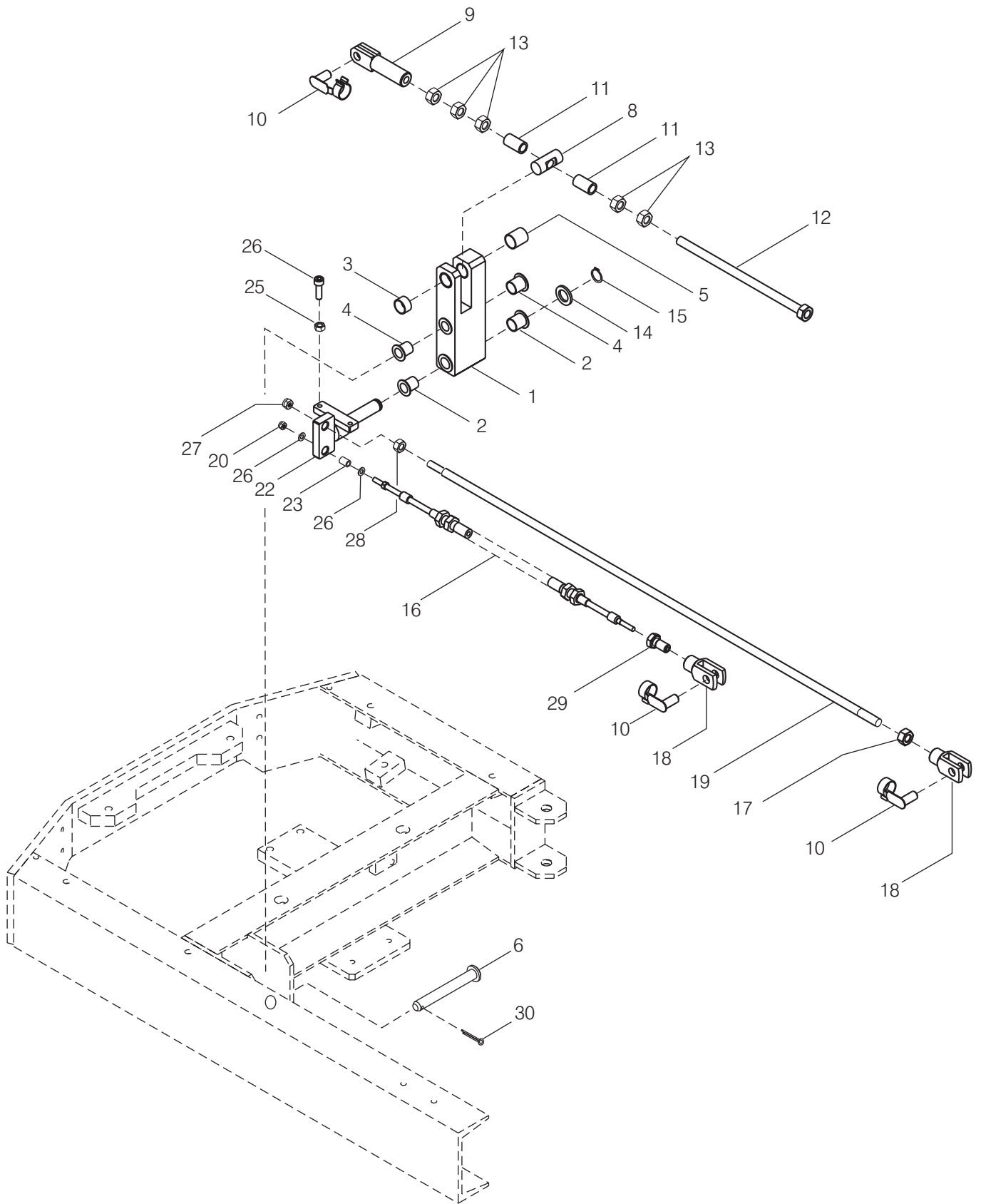

Bremsumlenkung

Pos	Art.Nr.	Stück	Bezeichnung	Description	Designation	Descrizione
1	20675300	1	Umlenkplatte	deviation plate	Tôle défectrice	panello di rinvio
2	20669400	2	Bundbuchse 14x16x22x17	bush 14x16x22x17	Manchon	boccola 14x16x22x17
3	20669500	1	Buchse Ø16x18x10	bush 16x18x10	Manchon	boccola 16x18x10
4	20797500	2	Bundbuchse PBG 121417 F	bush	Manchon	boccola
5	20797600	1	Buchse PG 161820 F	bush	Manchon	boccola
6	20667000	1	Bolzen mit kleinem Kopf	bolt	Boulon	bullone
8	20674000	1	Drehbolzen	torsional bolt	Tourillon	bullone di rotazione
9	20674100	1	Druckgabel	pressure fork	Fourche de compression	forcella a pressione
10	20631000	3	Federklappbolzen 10x20	snap-on clip 10x20	Étrier de ressort 10x20	bullone di fissaggio
11	20674200	2	Distanzrohr	distance tube	Distancier	tubo distanziatore
12	20675500	1	Druckstange	pressure bar	Tige de compression	barra a pressione
13	20054400	5	6-Kantmutter M10	hex. nut M10	Écrou M10	dado esagonale M10
14	20680400	1	Scheibe 15,0x24,0x2,5 DIN433	washer 15x24x2,5	Rondelle 15x24x2,5	rondella 15
15	20296800	1	Sicherungsring I 14x1 DIN471	safety ring I 14x1	Rondelle de sécurité I 14x1	anello di sicurezza I 14x1
16	20669600	1	Zug-Druck-Kabel	hauling and carrying cable	Fil de traction-pression	cavo di trazione e pressione
17	20626400	1	6-Kantmutter M10 DIN936	hex. nut M10	Écrou M10	dado esagonale M10
18	20627200	2	Gabelkopf G10x20	fork head	Tête à fourche G10x20	testa di forcella
19	20675100	1	Zugstange	drawbar	Tirant	barra di trazione
20	20046030	1	6-Kantmutter M5 STOPP DIN985	hex. nut M5 Stop	Écrou M5 Stopp	dado esagonale M5
22	20782300	1	Wippachse	rocker axle	Éssieu basculante	asse a bilico
23	20782200	1	Distanzbuchse	distance bush	Manchon	boccola distanziatore
24	20082600	2	Zylinderschraube M 6x16 DIN912	screw M6x16	Vis cylindrique M6x16	vite tc M6x16
25	20002000	2	6-Kantmutter M6 DIN934	hex. nut M6	Écrou M6	dado esagonale M6
26	20009600	2	Scheibe 5,3 DIN125	washer 5,3	Rondelle 5,3	rondella 5,3
27	20280500	1	6-Kantmutter M8 STOPP DIN985	hex. nut M8 Stop	Écrou M8 Stopp	dado esagonale M8
28	20000500	1	6-Kantmutter M8 DIN934	hex. nut M8	Écrou M8	dado esagonale M8
29	20679400	1	Schraube Bremsarm	brake arm screw	Vis	vite braccio freno
30	20682000	1	Splint 3,2x25	cotter pin	Goupille	chiavetta

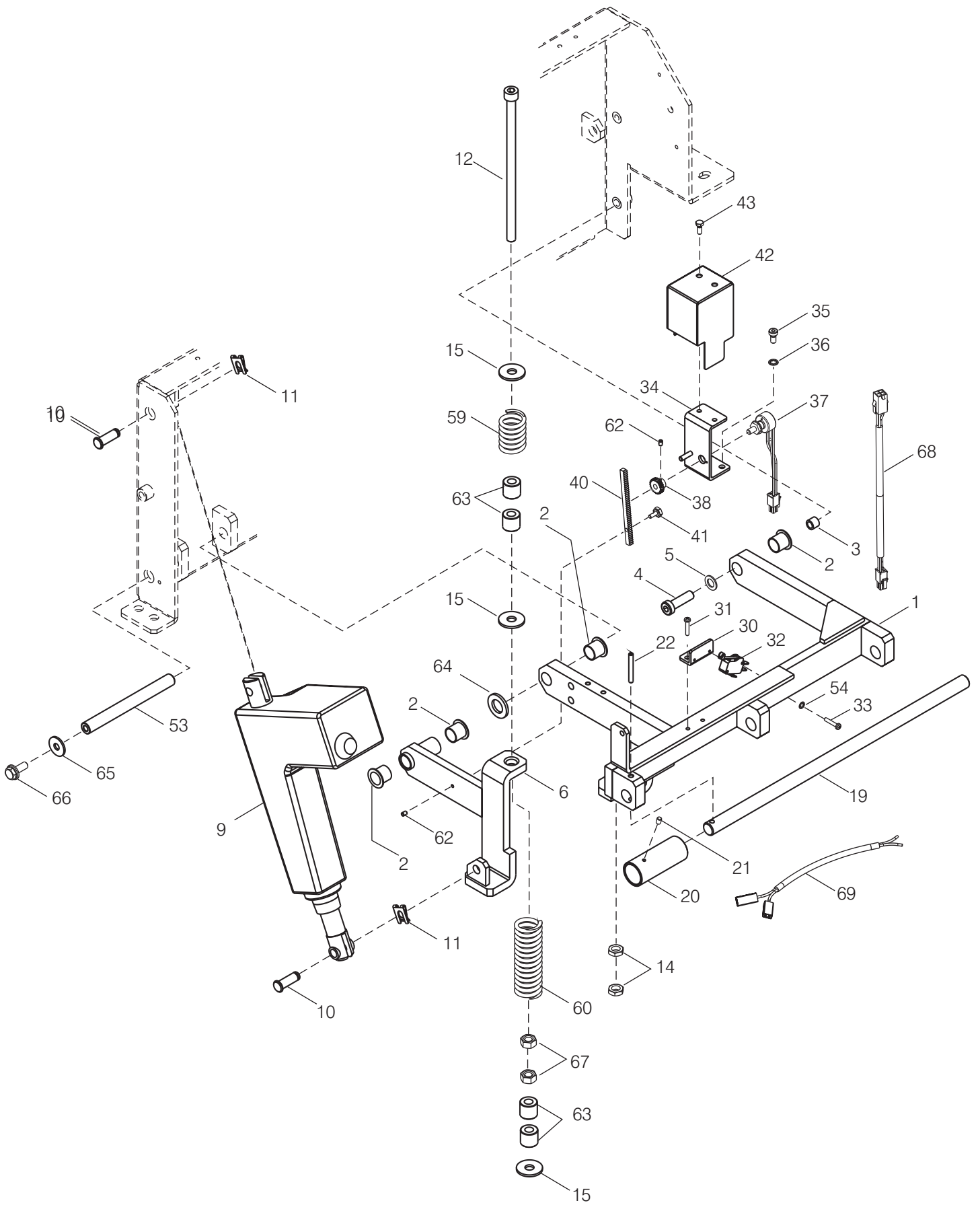

Schwenkeinheit

Pos	Art.Nr.	Stück	Bezeichnung	Description	Designation	Descrizione
1	20678900	1	Schwenkeinheit	swivel unit	Ensemble pivotant	unità direttore
2	20669400	4	Bundbuchse BB 1417 DU	bush	Manchon	boccola
3	20672600	1	Schraubrohr	screwed tube	Tube fileté	tubo filettato
4	20682500	1	Zylinderschraube M10x35 DIN912	screw M10x35	Vis cylindrique M10x35	vite tc M10x35
5	20054500	1	Scheibe 10,5x18,0x1,4 DIN433	washer 10,5x18x1,4	Rondelle 10,5x18x1,4	rondella 10,5
6	20677700	1	Linakhebel	lever	Levier	leva Linak
9	20627300	1	Verstellantrieb RA100 bis Masch.Nr. 703 Verstellantrieb verstärkt ab Masch.Nr. 704	adjustable drive	Entraînement réglable	motore regolabile
10	20371802	2	Bolzen	bolt	Boulon	bullone
11	20373900	2	SL-Sicherung 10MBO 08	safety piece 10mbo	Collier d'épaulement 10 MBO 08	pezzo di sicurezza 10
12	20680500	1	Zylinderschraube M10x200 DIN912	screw M10x200	Vis cylindrique M10x200	vite tc M10x200
14	20054400	2	6-Kantmutter M10 DIN934	hex. nut M10	Écrou M10	dado esagonale M10
15	20641300	3	Scheibe Ø28 DIN9021	washer Ø28	Rondelle Ø28	rondella Ø28
19	20674600	1	Tragstab	carrying bar	Barre	barra portante
20	20685800	1	Schalterrohr	switching tube	Tube culissante	tubo interruttore
21	20153800	1	Gewindestift M4x 6 DIN916	headless screw M4x6	Vis (sans tête) M 4x6	spina filettata M4x6
22	20670600	1	Spannstift 5x40 DIN1481	stud	Groupille 5x40	spina tenditore 5x40
19	20674600	1	Tragstab	carrying bar	Barre	barra portante
20	20685800	1	Schalterrohr	switching tube	Tube culissante	tubo interruttore
21	20153800	1	Gewindestift M4x 6 DIN916	headless screw M4x6	Vis (sans tête) M 4x6	spina filettata M4x6
22	20670600	1	Spannstift 5x40 DIN1481	stud	Groupille 5x40	spina tenditore 5x40
30	20685700	1	Schalterwinkel	switch support	Angle	angolo interruttore
31	20004800	2	Linsenschraube M 6x12 DIN7985	lens screw M6x12	Vis à tête bombée M6x12	vite M6x12
32	20958800	1	Microschalter 1006.1514 10(6)A	micro switch	Microcommutateur	microinterruttore
33	20018400	2	Linsenschraube M 3x16 DIN7985	lens screw M3x16	Vis à tête bombée M3x16	vite M3x16
34	20674700	1	Potihalter	potentiometer support	Fixation	supporto potenziometro
35	20151900	2	Zylinderschraube M 6x12 DIN7984	screw M6x12	Vis cylindrique M6x12	vite tc M6x12
36	20008000	2	Zahnscheibe J 6,4 DIN6797	lock washer J 6,4	Rondelle dentée J6,4	disco dentato J6,4
37	20681130	1	Potentiometer 10 KOhm mit Kabel und AMP-Stecker ab Seriennr.862	potentiometer 10 K Ohm	Potentiomètre 10K	potenziometro 10K
38	20670100	1	Poti-Zahnrad m=0,7	toothed wheel m=0,7	Roue dentée	ruota dentata m=0,7
40	20670200	1	Poti-Zahnstange m=0,7	toothed bar m=0,7	Crémaillère	cremaliera m=0,7
41	20670700	1	Flachkopfschraube M3x6 DIN923	screw M3x6	Boulon à tête plate M3x6	vite M3x6
42	20674900	1	Potiabdeckung	potentiometer cover	Couverture	coperchio potenziometro
43	20119500	2	6-Kantschraube M 5x12 DIN933	hex. screw M5x12	Vis à tête hex.M8x45	vite esagonale M5x12

Schwenkeinheit

POS	Art.Nr.	Stück	Bezeichnung	Description	Designation	Descrizione
53	20770900	1	Schwenkbolzen	swivel bolt	Boulon basculant	bullone girevole
54	20165400	2	Zahnscheibe J 3,2	lock washer J 3,2	Rondelle dentée J3,2	disco dentato J3,2
59	20806300	1	Druckfeder D339O	pressure spring	Ressort de traction	molla di compressione D-339O
60	20761200	1	Druckfeder D339Q	pressure spring	Ressort de traction	molla di compressione D-339Q
62	20153800	2	Gewindestift M4x6 DIN916	headless screw M4x6	Vis (sans tête) M 4x6	spina filettata M4x6
63	20800900	4	Distanzrohr	bush	Douille	manicotto
64	20627500	1	Scheibe PA 17x30x3	washer PA 17x30x3	Rondelle 17x30x3	rondella PA 17x30x3
65	20633730	1	Scheibe 8,4 DIN9021	washer 8,4	Rondelle 8,4	rondella 8,4
66	20195300	1	Verbusschr. M8x20	screw M8x20	Vis M8x20	vite M8x20
67	20682400	2	6-Kantmutter M10 STOPP DIN985	hex. nut M10	Écrou M10	dado esagonale M10
68	20928201	1	Kabel Druckpoti ab Seriennr.862	cable for potentiometer	Câble	cavo potenziometro
69	20823000	1	Kabel Microschalter- Bürstaggreat	cable microswitch- brush drive	Câble	cavo micro interruttore

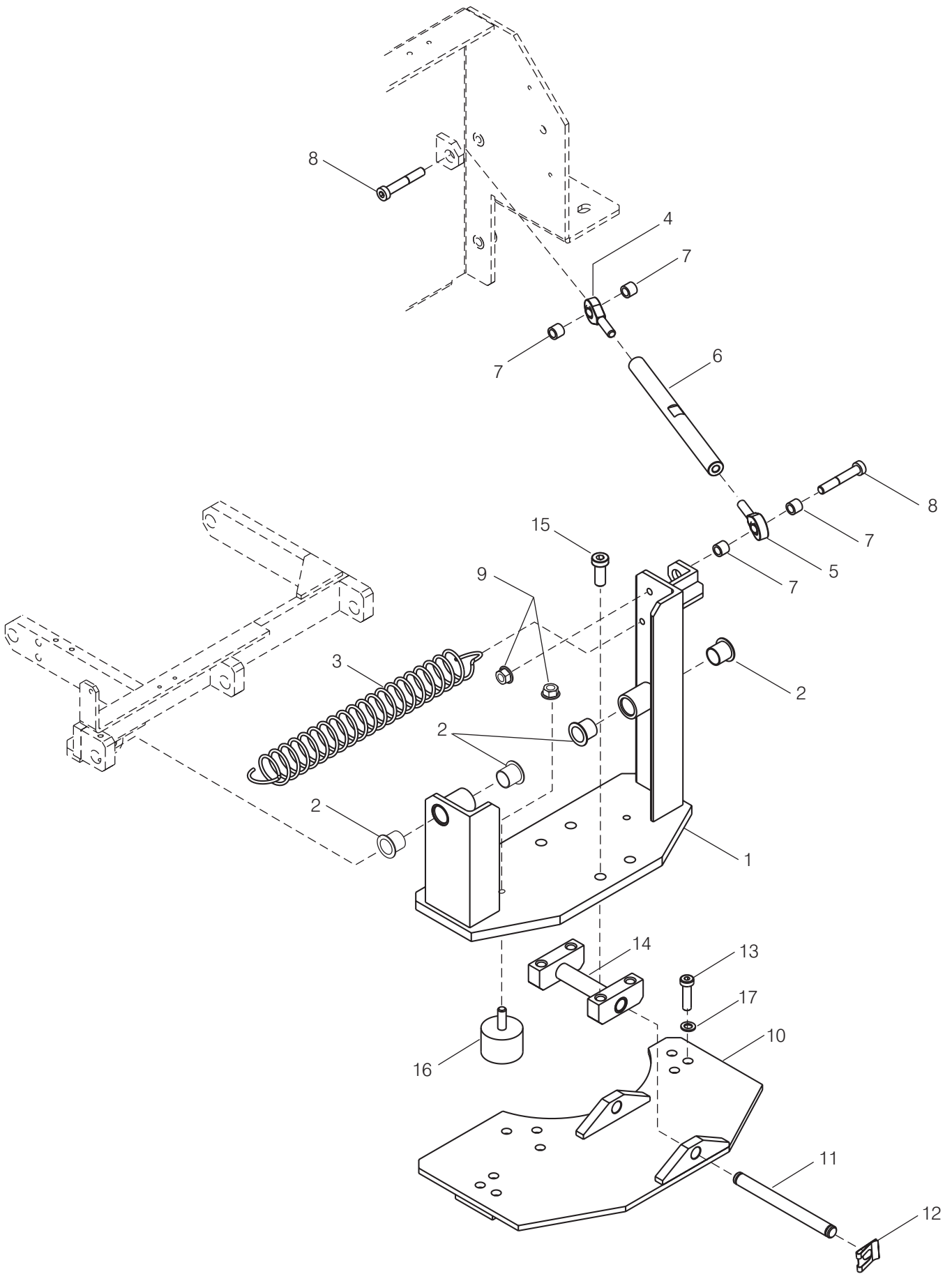

Bürstanhebung

Pos	Art.Nr.	Stück	Bezeichnung	Description	Designation	Descrizione
1	20679200	1	Hebeeinheit	lifting unit	Ensemble levage	unità di sollevamento
2	20669900	4	Bundbuchse GFM-1618-17	bush	Manchon	bocola
3	20670500	1	Zugfeder RZ-162U-20I	traction spring	Ressort de traction	molla di trazione RZ-162U-20I
4	20670300	1	Gelenkkopf m. Mutter M8 re.	fork set screw	Articulation	vite a forcella M8
5	20670400	1	Gelenkkopf m. Mutter M8 li.	fork set screw	Articulation	vite a forcella M8
6	20674400	1	Gelenkkopfaufnahme	seat	Logement	alloggiamento vite a forcella
7	20674300	4	Abstandshülse	distancer	Distancier	manicotto distanziatore
8	20178400	2	Zylinderschraube M 8x45 DIN6912	screw M8x45	Vis cylindrique M8x45	vite tc M8x45
9	20045900	3	Verbusmutter M8	hex. nut M8	Écrou M8	dado esagonale M8
10	20679000	1	Bürstanschraubung	support brushes	Fixation	supporto spazzole
11	20672700	1	Kippachse	tilting axle	Axe de renversement	asse ribaltabile
12	20373800	2	SL-Sicherung 12MBO 08	safety piece 12mbo	Collier d'épaulement 12 MBO 08	pezzo di sicurezza 12 MBO 08
13	20279100	9	Zylinderschraube M 8x30 DIN7984	screw M8x30	Vis cylindrique M8x30	vite tc M8x30
14	20785100	1	Bürstaufhängung	support brushes	Suspension	sospensione spazzole
15	20679900	4	Zylinderschraube M10x25 DIN7984	screw M10x25	Vis cylindrique M10x25	vite tc M10x25
16	20802000	2	Gummipuffer	bumper	Tampon	tampone a gomma
17	20005500	9	Sicherungsscheibe SMZ 8	washer 8	Rondelle 8	rondella 8

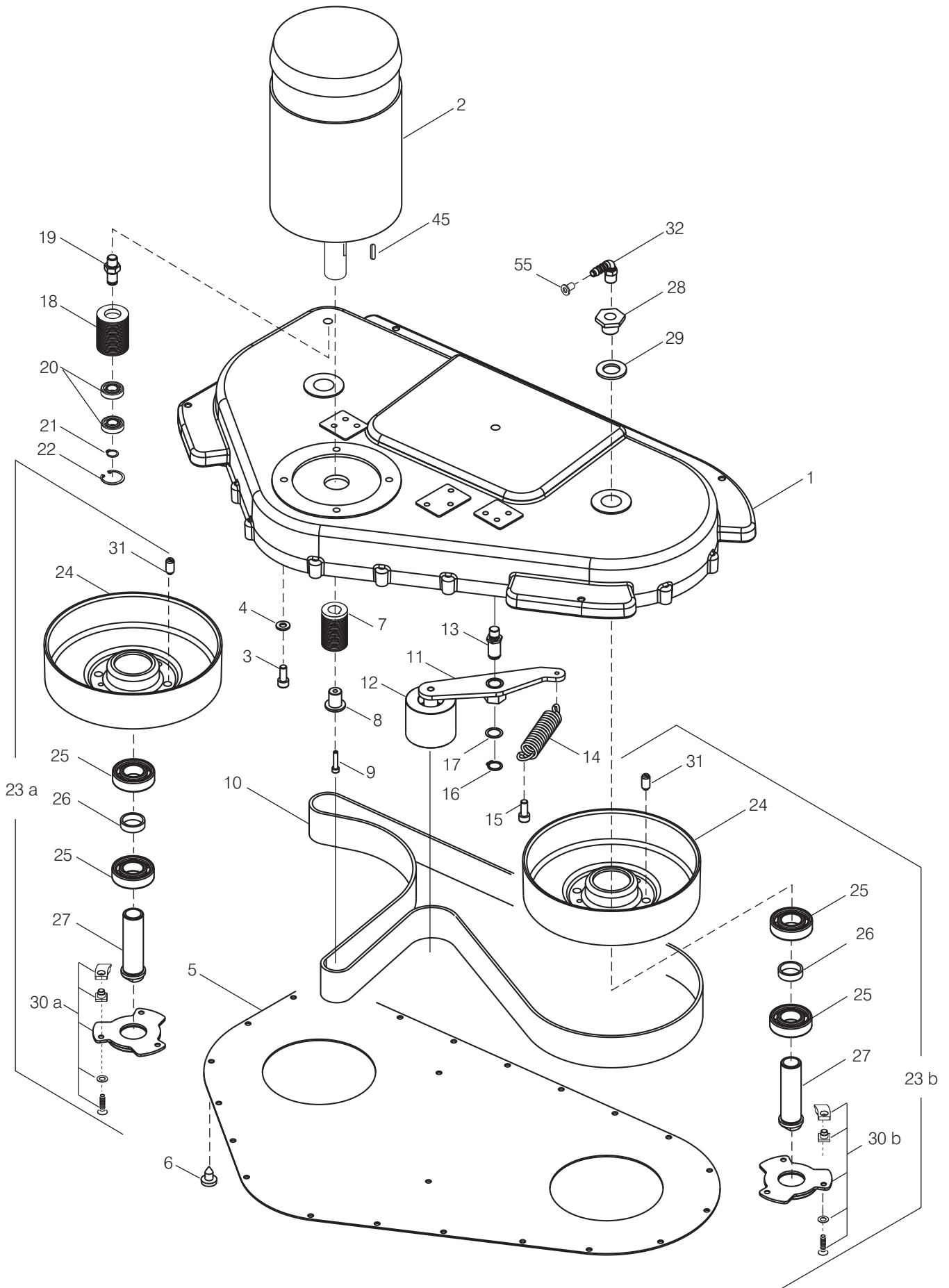

columbus

**ARA 80|BM 150
ARA 100|BM 150**

Bürstantrieb

Pos	Artikel Nr.	Stück	Bezeichnung	Description	Designation	Descrizione
	20636533		Bürstantrieb 80 ERSATZ	Brush drive 80 kpl.	Entraînement de brosse 80 compl.	motore spazzola 80 compl.
	20634433		Bürstantrieb 100 ERSATZ	Brush drive 100 kpl.	Entraînement de brosse 100 compl.	motore spazzola 100 compl.
1	20636500	1	Getriebedeckel 80	gear cover	Carcasse	copertura spazzola
	20634400	1	Getriebedeckel 100	gear cover	Carcasse	copertura spazzola
2	20243100	1	Motor 24V/1 KW (80)	motor 24V/1 KW	Moteur de brosse 1 KW	motore 24V/1 KW
	20634501	1	Motor 24V/1,5 KW (100) bis SN747	motor 24V/ 1,5 KW	Moteur de brosse 1,5 KW	motore 24V/1,5 KW
	20243100	1	Motor 24V/1 KW (100) abSN. 748	motor 24V/1 KW	Moteur de brosse 1 KW	motore 24V/1 KW
	20265600	2	Kohlebürste für 20243100	carbon brush	balai en charbon	spazzola di carbone
	20634509	2	Kohlebürste für 20634501	carbon brush	balai en charbon	spazzola di carbone
3	20029200	4	Zylinderschraube M8x25 DIN7984	cap screw M8x25	Vis cylindrique M8x25	vite cilindrica M8x25
4	20067600	4	Scheibe 8,4 DIN125	washer 8,4	Rondelle 8,4	rondella 8,4
5	20640000	1	Abdeckplatte 80	cover	Couverture	copertura
	20637000	1	Abdeckplatte 100	cover	Couverture	copertura
6	20036000	10	Linsenschraube CM5x10 DIN7500	lens screw CM5x10	Vis à tête bombée CM5x10	vite CM5x10
7	20782800	1	Rillenritzel	groove pinion	Pignon	pignone scanalato
8	20640800	1	Bolzen für Rillenritzel	bolt for groove pinion	Boulon	bullone per pignone scanalato
9	20013200	1	Zylinderschraube M5x25 DIN912	cap screw M5x25	Vis cylindrique M5x25	vite cilindrica M5x25
10	20760800	1	Riemen J20/1895 (80)	belt J20/1895 (80)	Courroie J20/1895 (80)	cinghia J20/1895 (80)
	20641600	1	Riemen J20/2210 (100)	belt J20/2210 (100)	Courroie J20/2210 (100)	cinghia J20/2210 (100)
11	20640430	1	Riemenspanner 80	belt tightener cpl.	Tendeur courroie	tendicinghia comp.
	20637230	1	Riemenspanner 100			
12	20640630	1	Spannrolle kpl.	idler pulley cpl.	Galopin de tension	puleggia di rinvio
13	20141301	1	Bolzen	bolt	Boulon	bullone
14	20374600	1	Zugfeder	extension spring	Ressort de traction	molla trazione
15	20278900	1	Zylinderschraube EM8x20 DIN7500	cap screw EM8x20	Vis cylindrique EM8x20	vite cilindrica EM8x20
16	20142400	1	Sicherungsring I 15x1 DIN471	safety ring I 15x1	Rondelle de sécurité I 15x1	seeger 15x1
17	20006100	1	Ausgleichsscheibe	washer (10 pieces)	Rondelle	rondella
18	20637500	1	Umlenkrolle Bürstaggreat	deflection pulley	Rouleau de renvoi	puleggia di rinvio
19	20246500	1	Bolzen	bolt	Boulon	bullone
20	20006000	2	Rillenkugellager 6001 2RS	bearing 6001 2RS	Roulement à billes	cucinetto 6001 2RS
21	20028900	2	Sicherungsring I 12x1 DIN471	safety ring I 12x1	Rondelle de sécurité I 12x1	seeger 12x1
22	20061900	2	Sicherungsring I 28x1,2	safety ring I 28x1,2	Rondelle de sécurité I 28x1,2	seeger 28x1,2
23a	20640340	1	Riemenscheibe li- 80	drive pulley left assy	Poulie pour courroie, gauche	puleggia trasmissione sin.cpl.
	20637140	1	Riemenscheibe li.100	drive pulley left assy	Poulie pour courroie, gauche	puleggia trasmissione sin.cpl.
23b	20640330	1	Riemenscheibe re. 80	drive pulley right assy	Poulie pour courroie, droite	puleggia trasmissione destra cpl.
	20637130	1	Riemenscheibe re. 100	drive pulley right assy	Poulie pour courroie, droite	puleggia trasmissione destra cpl.

Bürstantrieb

Pos	Art.Nr.	Stück	Bezeichnung	Description	Designation	Descrizione
24	20640300	2	Riemenscheibe 80	drive pulley	Poulie pour courroie	puleggia transmiss.
	20637100	2	Riemenscheibe 100	drive pulley	Poulie pour courroie	puleggia transmiss.
25	20140700	4	Rillenkugellager 6205 2RS	bearing 6205 2RS	Roulement à billes	cucinetto 6205 2RS
26	20141701	2	Zwischenring	intermediate ring	Rondelle intermédiaire	seeger intermedio
27	20637400	2	Welle	shaft	Arbre	albero
28	20372500	2	Mutter für Riemenscheibe	hex nut for beltplate	Écrou	dado per puleggia
29	20373400	2	Scheibe A21 DIN125	washer A21	Rondelle A21	rondella A21
30a	20609331	1	Segmentscheibe links ab SN.817	segment washer left assy	Meule segmentée, gauche	flangia sinistra cpl.
30b	20609231	1	Segmentscheibe rechts ab SN.817	segment washer right assy	Meule segmentée, droite	flangia destra cpl.
31	20220900	6	Druckstück federnd	pressure piece	groupille de pression	pezzo di pressione elastico
32	20365100	2	Einschraubstutzen 90 GR M14x1,5	screwed connection 90 GR M14x1,5	Tubulure d'équerre	boccola a vite 90 GR M14x1,5
45	20249000	1	Passfeder 5x5x17	feather key	Ressort d'ajustage	linguetta di aggiustamento
55	20269001	2	Drossel	throttle	Restricteur	farfalla

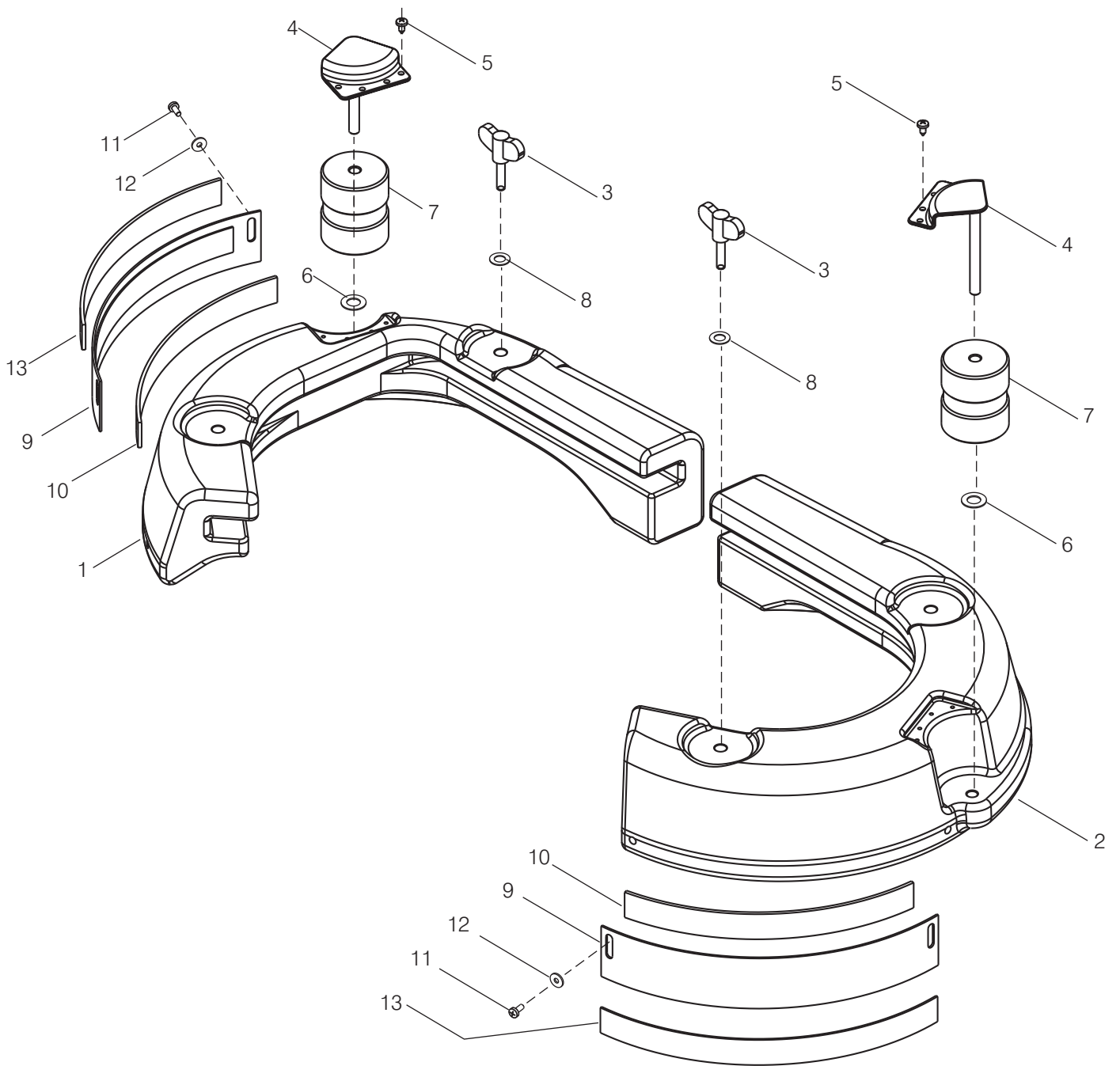

Bürstabdeckung 80

Pos	Art.Nr.	Stück	Bezeichnung	Description	Designation	Descrizione
1	20640101	1	Bürstabdeckung links 15°	brush cover left 15°	Couvercle de brosse gauche	copertura spazzola sinistra 15°
2	20640201	1	Bürstabdeckung rechts 15°	brush cover right 15°	Couvercle de brosse droite	copertura spazzola destra 15°
3	20641400	4	Flügelschraube	wing screw	Boulon à ailettes	vite ad alette
4	20641500	2	Platte für Abweisrolle	plate for protection castor	Plaque	piastrina per ruota protezione
5	20816200	12	Schraube KA 50x16 schw. EJOT	screw KA 50x16	Vis KA50x16	vite KA 50x16
6	20373700	2	Scheibe 20x11x1 PVC DIN125	washer 20x11x1 PVC	Rondelle 20x11x1	rondella 20x11x1 PVC
7	20363600	2	Abweisrolle Ø66xØ10,5x80	protecting castor Ø66xØ10,5x80	Roulette de protection 66x10,5x80	ruota di protezione Ø66xØ10,5x80
8	20067600	4	Scheibe 8,4 DIN125	washer 8,4	Rondelle 8,4	rondella 8,4
9	20782600	2	Spritzschutz	splash protection	Protection contre les projections	lamiera paraspruzzi
10	20790001	2	Hakenband L=300mm	ribbon L=300mm	Band	volume L=300 mm
11	20278000	4	Linsenschraube M5x12 DIN7985	lens screw M5x12	Vis à tête bombée M5x12	vite M5x12
12	20112900	4	Scheibe 5,3 DIN9021	washer 5,3	Rondelle 5,3	rondella 5,3
13	51058200	2	Gurtband L=535	webbing	Band	banda

Bürstabdeckung 100

Pos	Artikel Nr.	Stück	Bezeichnung	Description	Designation	Descrizione
1	20634301	1	Bürstabdeckung links 15°	brush cover left 15°	Couvercle de brosse gauche	copertura spazzola sinistra 15°
2	20634201	1	Bürstabdeckung rechts 15°	brush cover right 15°	Couvercle de brosse droite	copertura spazzola destra 15°
3	20641400	4	Flügelschraube	wing screw	Boulon à ailettes	vite ad alette
4	20641500	2	Platte für Abweisrolle	plate for protection castor	Plaque	piastrina per ruota protezione
5	20816200	12	Schraube KA 50x16 schw. EJOT	screw KA 50x16	Vis KA50x16	vite KA 50x16
6	20373700	2	Scheibe 20x11x1 PVC DIN125	washer 20x11x1 PVC	Rondelle 20x11x1	rondella 20x11x1 PVC
7	20363600	2	Abweisrolle Ø66xØ10,5x80	protecting castor Ø66xØ10,5x80	Roulette de protection 66x10,5x80	ruota di protezione Ø66xØ10,5x80
8	20067600	4	Scheibe 8,4 DIN125	washer 8,4	Rondelle 8,4	rondella 8,4
9	20782700	2	Spritzschutz	splash protection	Protection contre les projections	lamiera paraspruzzi
10	20790002	2	Hakenband L=380mm	ribbon L=380mm	Band	volume L=380 mm
11	20278000	4	Linsenschraube M5x12 DIN7985	lens screw M5x12	Vis à tête bombée M5x12	vite M5x12
12	20112900	4	Scheibe 5,3 DIN9021	washer 5,3	Rondelle 5,3	rondella 5,3
13	51058200	2	Gurtband L=535	webbing	Band	banda

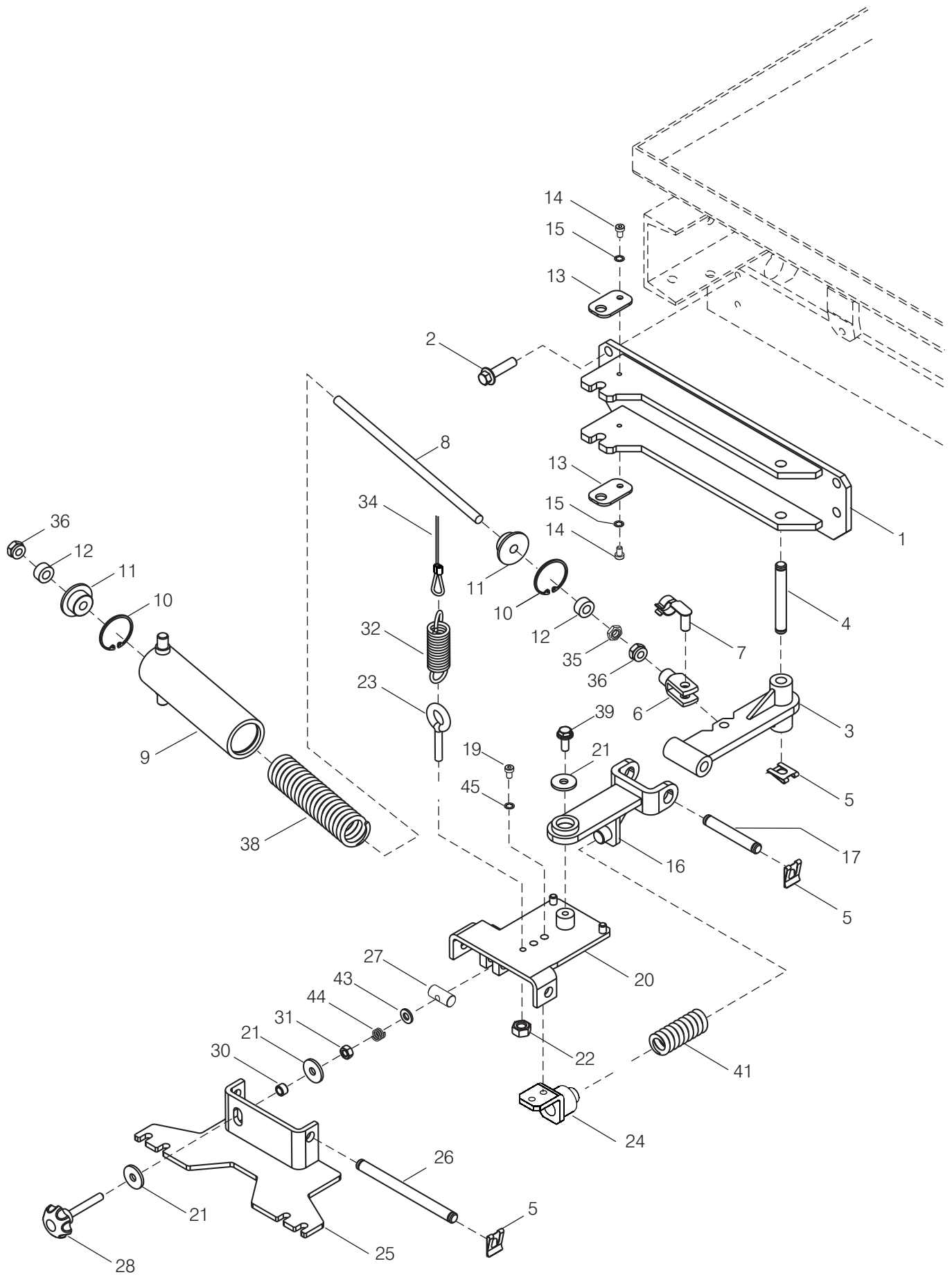

Düsenaufnahme

Pos	Art.Nr.	Stück	Bezeichnung	Description	Designation	Descrizione
1	20800000	1	Anschraubeinheit	fixing unit	Ensemble fixation	unità avvitanento
2	20681600	4	Verbusschr. M10x25	hex. screw M10x25	Vis M10x25	vite esag. M10x25
3	20800400	1	Federarm	feather arm	Bras élastique	braccio molleggiante
4	20800600	1	Drehbolzen	rotatable bolt	Tourillon	bullone di raotazione
5	20373800	6	SL-Sicherung 12	safety piece 12mbo	Collier d'épaulement 12	pezzo di sicurezza 12
6	20627200	1	Gabelkopf G10x20	fork set screw 10x20	Tête à fourche G10x20	testa di forcella G10x20
7	20631000	1	Federklappbolzen 10x20	snap-on clip 10x20	Étrier de ressort 10x20	bullone di fissaggio 10x20
8	20800100	1	Federstange	feather bar	Barre élastique	barra molleggiante
9	20800200	1	Federrohr	feather tube	Tube élastique	tubo molleggiante
10	20801400	2	Sicherungsring I 40x1,75 DIN472	safety ring I 40x1,75	Rondelle de sécurité I 40x1,75	anello di sicurezza I 40x1,75
11	20800300	2	Federscheibe	feather washer	Rondelle élastique	rondella molleggiante
12	20800900	2	Distanzrohr	distance tube	Distancier	tubo distanziatore
13	20800800	2	Halteblech	haoding plate	Fixation	supporto
14	20193000	2	Zylinderschr. M6x10	screw M6x10	Vis cylindrique M6x10	vite tc M6x10
15	20008000	2	Zahnscheibe J 6,4	lock washer J 6,4	Rondelle dentée J6,4	disco dentato J6,4
16	20800500	1	Kipphebel	tiltable lever	Levier basculant	leva ribaltabile
17	20800700	1	Kippbolzen	tiltable bolt	Boulon basculant	bullone ribaltabile
19	20152000	2	Zylinderschr. M8x16	screw M8x16	Vis cylindrique M8x16	vite tc M8x16
20	20801000	1	Düsenträger	nozzle support	Support	portante bocchetta
21	20277800	3	Scheibe 9x28,0x3	washer 9x28x3	Rondelle 9x28x3	rondella 9x28x3
22	20280500	1	6-Kantmutter M 8	hex. nut M8	Écrou M8	dado esagonale M8
23	20801500	1	Ringschraube M8x40	ring bolt	Vis à boucle	vite ad anello M8x40
24	20801200	1	Federwinkel kurz	feather angle short	Angle	angolo, corto
25	20634100	1	Düsenhalter	nozzle holder	Support	supporto bocchetta
26	20619800	1	Bolzen Ø12	bolt Ø12	Boulon	bullone Ø12
27	20801300	1	Gelenk Düsenneigung	nozzle incline articulation	Articulation	cerniera
28	20585500	1	Sterngriffschraube M8x45	star grip screw M8x45	Vis avec poignée étoile M8x45	vite a stella M8x45
30	20619900	1	Distanzbuchse Ø12/8x7	distance bush Ø12/8x7	Distancier	distanziale Ø12/8x7
31	20297300	2	6-Kantmutter M 8 Ms flach DIN439	hex. nut M8 flat	Écrou M8	dado esagonale M8
32	20568500	1	Zugfeder	tension spring	Ressort de traction	molla di trazione
34	20801731	1	Seilzug Gerätedüse	steel rope Ø3	Câble d'acier	strallo Ø3
35	20626400	1	6-Kantmutter M 10, niedrig DIN936	hex. nut M10 low	Écrou M10	dado esagonale M10
36	20682400	2	6-Kantmutter M 10 Stopp DIN985	hex. nut M10 stop	Écrou M10 Stopp	dado esagonale M10
38	20803500	1	Druckfeder	pressure spring	Ressort de compression	molla di compressione
39	20195300	1	Verbusschr. M8x20	hex. screw M8x20	Vis M8x20	vite esagonale M8x20
41	20868800	1	Druckfeder D-365RA	pressure spring D-365RA	Ressort de compression	molla di compressione D-365RA
43	20067600	1	Scheibe 8,4x17x2	washer 8,4x17x2	Rondelle 8,4	rondella 8,4
44	20856100	1	Druckfeder D-207KA	pressure spring D-207KA	Ressort de compression	molla di compress. D-207KA
45	20005500	2	Zahnscheibe J 8,4	lock washer J 8,4	Rondelle dentée J8,4	disco dentato J8,4

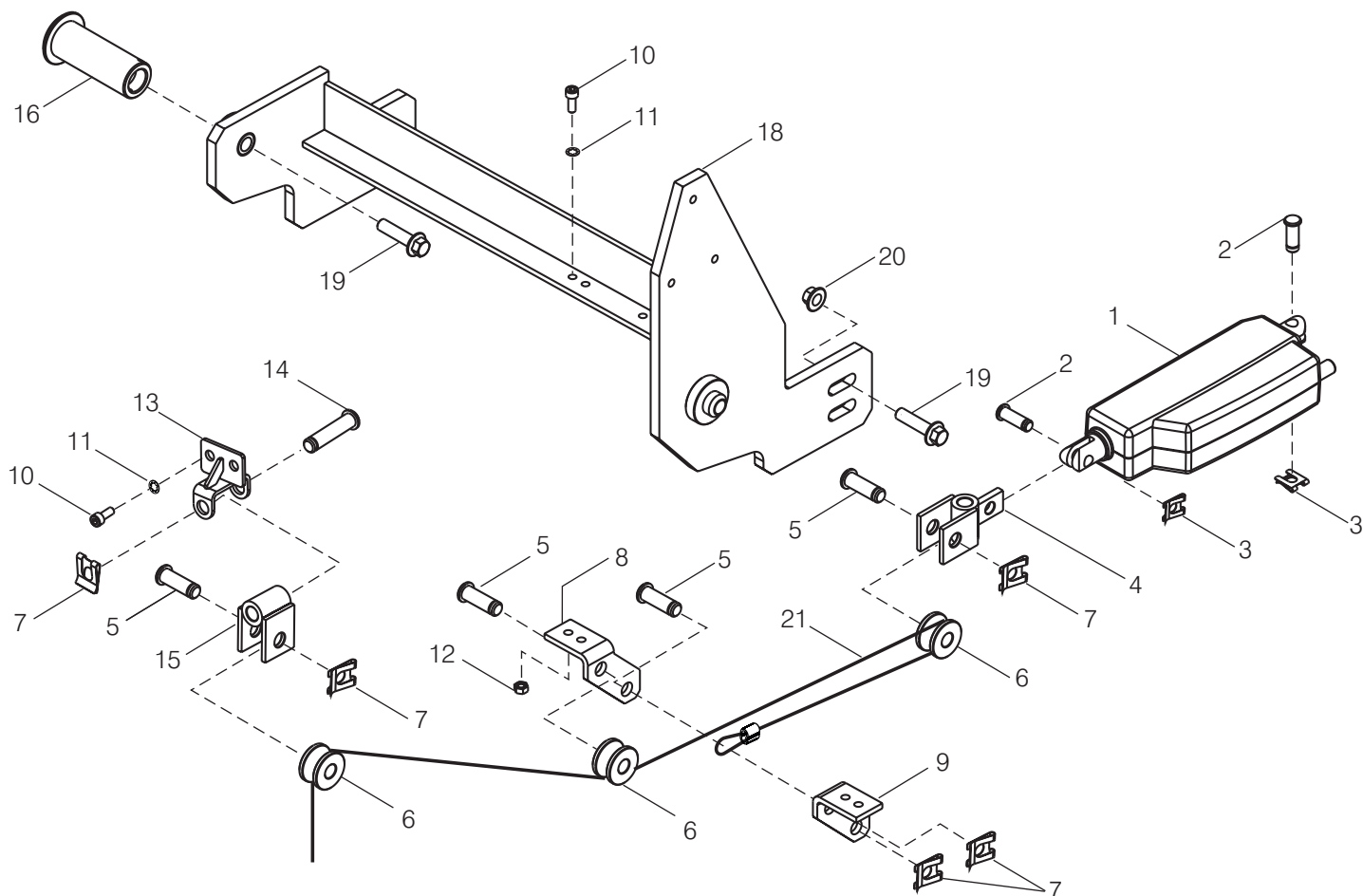

Düsenanhebung

Pos	Art.Nr.	Stück	Bezeichnung	Description	Designation	Descrizione
1	20630900	1	Verstellantrieb RA100	adjustable drive	Entraînement réglable	motore regolabile
2	20642000	2	Bolzen	bolt	Boulon	bullone
3	20373900	2	SL-Sicherung 10	safety piece 10	Collier d'épaulement	pezzo di sicurezza 10
4	20673600	1	Linakumlenkung	deflection	Dispositif de renvoi	rinvio
5	20636600	4	Bolzen	bolt	Boulon	bullone
6	20635500	3	Umlenkrolle	deflection roll	Rouleau de renvoi	pulleggia di rinvio
7	20373800	4	SL-Sicherung 12	safety piece 12	Collier d'épaulement	pezzo di sicurezza 12
8	20675700	1	Winkel rechts	angle right	Angle droite	angolo, destro
9	20675800	1	Winkel links	angle left	Angle gauche	angole, sinistra
10	20152000	6	Zylinderschr. M8x16	screw M8x16	Vis cylindrique M8x16	vite M8x16
11	20005500	6	Zahnscheibe J 8,4	lock washer J 8,4	Rondelle dentée J8,4	disco dentato J8,4
12	20002000	4	6-Kantmutter M6	hex. nut M6	Écrou M6	dado esagonale M6
13	20676200	1	Tankbügel	fastening	Bride	staffa serbatoio
14	20635300	1	Bolzen f.Umlenkrolle	bolt	Boulon	bullone
15	20635400	1	Halter f.Umlenkrolle	holder tank	Support	supporto
16	20676000	2	Lagerung	bearing	Logement	alloggiamento
18	20678300	1	Tankträger	support tank	Support	portante serbatoio
19	20681600	5	Verbusschr. M10x25	hex. screw M10x25	Vis M10x25	vite esag. M10x25
20	20681700	4	Verbussmutter M10	hex. nut M10	Écrou M10	dado esagonale M10
21	20801731	1	Seilzug Gerätedüse	steel rope Ø3	Câble d'acier	strallo Ø3

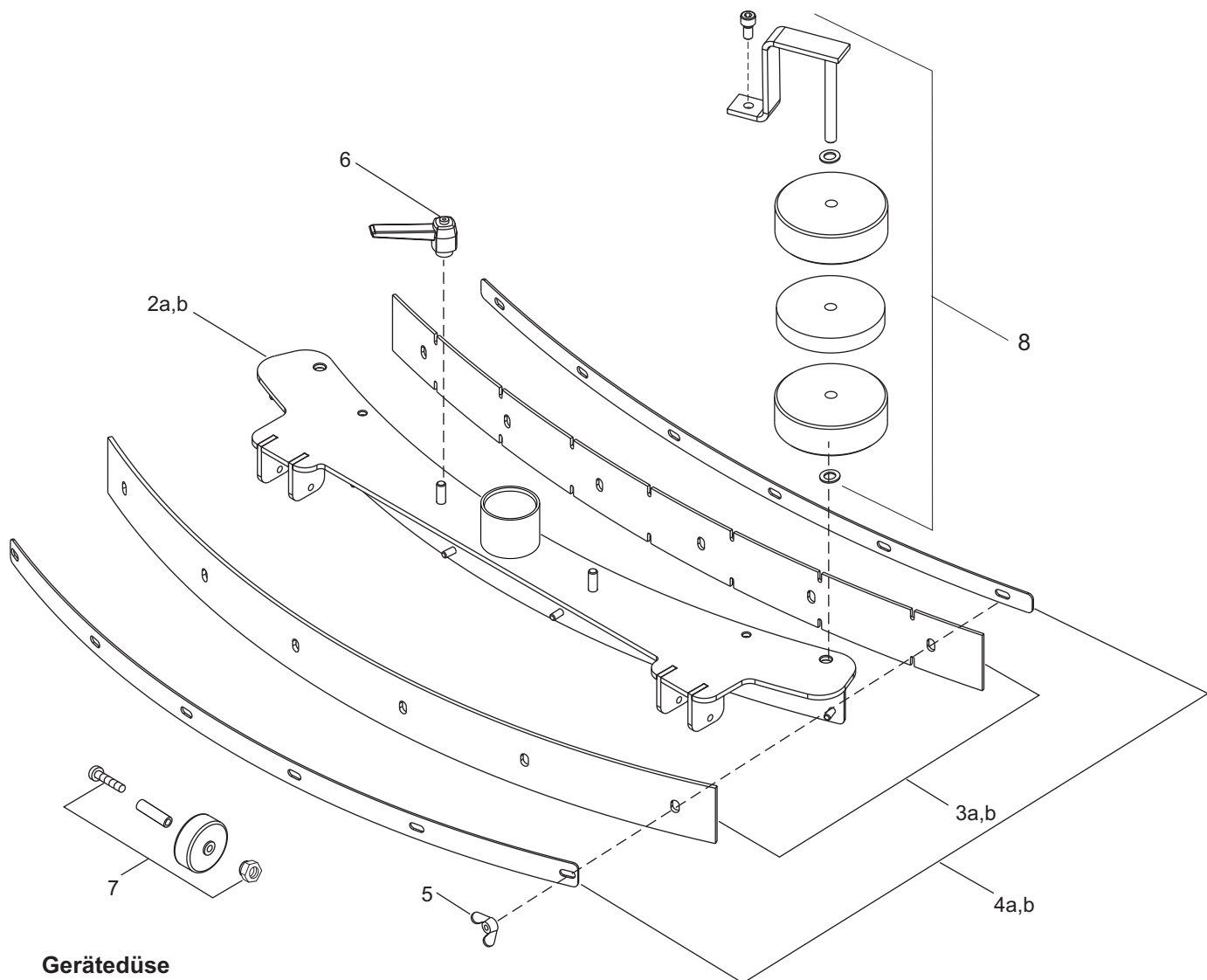

Gerätedüse

Pos	Art.Nr.	Stück	Bezeichnung	Description	Designation	Descrizione
	20646231	1	Gerätedüse 80 kpl.	squeegee tool 80 cpl	Buse d'aspiration 80 compl.	bocchetta 80 compl.
	20647031	1	Gerätedüse 100 kpl.	squeegee tool 100 cpl.	Buse d'aspiration 100 compl.	bocchetta 100 compl.
2	20646202	1	Gerätedüse 80	squeegee tool 80	Buse d'aspiration 80	bocchetta 80
2	20647002	1	Gerätedüse 100	squeegee tool 100	Buse d'aspiration 100	bocchetta 100
3	20645831	1	Sauglippen-Satz 80	squeegee blades set 80	Set raclette 80	set lamelle 80
3	20646631	1	Sauglippen-Satz 100	squeegee blades set 100	Set raclette 100	set lamelle 100
4	20646030	1	Klemmleiste Satz 80	clamping strip set 80	Fixation (set) 80	set piattina bloccagomma 80
4	20646830	1	Klemmleiste Satz 100	clamping strip set 100	Fixation (set) 100	set piattina bloccagomma 100
5	20623130	1	Flügelmutter M6 (12 Stück)	nut set (12 pieces)	Ecrou (set-12 pieces)	dado a farfalla, set
6	20783230	2	Klemmhebel M8 (2 Stück)	clamping lever set (2 pieces)	Levier pour fixation (set)	leva di fissaggio M8, set
7	20442433	2	Gummirolle	guide roll	Rouleau d'appui	ruota
8	20621431	2	Abweisrolle kpl.	high protecting caster	Roulette de protection	ruota di protezione

Änderungen im Zuge technischer Verbesserungen sind vorbehalten !
We reserve the right to effect modifications within the framework of technical progress !
Sous réserve de modification dans le cadre des développements techniques !
Essendo la nostra un'impresa a carattere innovativo, ci riserviamo la possibilità di apportare modifiche tecniche !

G. Staehle GmbH u. Co. KG
columbus Reinigungsmaschinen
Mercedesstr. 15
D - 70372 Stuttgart
Telefon +49(0)711 / 9544-950
Telefax +49(0)711 / 9544-941

info@columbus-clean.com
www.columbus-clean.com

70087000

columbus